

Performance Analysis of Gasification Coupled with IC Engine for Emission Control : Enhancing Environmental Sustainability

S. Sivakumar

Department of Mechanical Engineering, Kumaraguru college of Technology.
E-mail: Sivakumar.siddhan.mec@kct.ac.in, telephone: 9940415348.

GRAPHICAL ABSTRACT

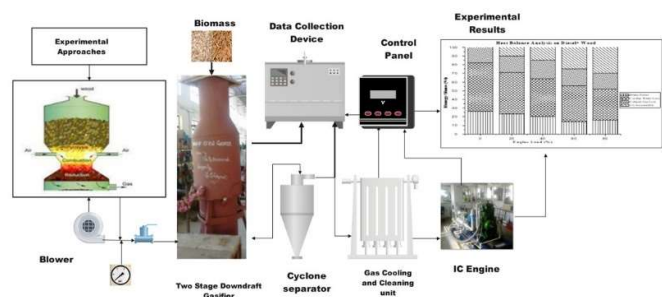

ABSTRACT

The gasification of biomass waste, such as Prosopis Juliflora wood(karuvellam wood), holds significant potential for reducing environmental impact and promoting sustainability. This study focused on investigating the gasification process of Prosopis Juliflora wood using a two stage air-preheated, Double throat downdraft gasifier.

This gasifier will create reduced emission and tar-free producer gas, which will aid in the operation of the internal combustion engine. Prosopis Juliflora wood's ideal parameter was calculated for different equivalent ratio. Prosopis Juliflora wood's producer gas composition and calorific value (CV) were found to be CO = 18.1%, H₂ = 12.7 %, and CV =

1092 kcal/Nm³. After determining the optimal operating point, the focus shifted to using this gas to power internal combustion engine in dual fuel mode. Diesel and producer gas from Prosopis Juliflora wood powered a 10 HP Field Marshall engine, single-cylinder, water-cooled, with a compression ratio of 16.6, coupled with an alternator and load bank. To compare the performance characteristics of diesel engines, combustion and emissions behaviours, were observed and analysed and a thorough analysis of the engine's behaviour during operation with producer gas was conducted. and a thorough analysis of the engine's behavior during operation with producer gas was conducted.

Keywords: Downdraft Gasifier, Double throat, gasification, IC Engine.

1 INTRODUCTION

India stands as one of the foremost energy consumers globally, as highlighted by Rathore et al (2009). Despite fossil fuels contributing a substantial 80% to the country's energy sources, they pose a significant environmental threat through the emission of pollutants such as NO_x, CO₂, and SO₂, as emphasized by chopra et al. (2007). IEA analysts foresee a nearly threefold rise in global biomass supply for modern bioenergy, from 37 EJ in 2020 to about 100 EJ by 2050, alongside renewable energy expansion (IEA energy report.2023). The aim is for this biomass to be harnessed for bioenergy production, constituting 18% of the total energy supply by 2050. This allocation includes 15% of energy consumption in industry, 16% in transport, and 10% in buildings (Debargha Banerjee et al. 2021). Thus, it is vital to support sustainable economic growth in India, which emphasizes the advancement and uptake of renewable energy resources and technologies.

Acknowledging this urgency, the World Energy Council has aligned with the consensus that addressing energy demand in India is paramount. Projections suggest a threefold increase by 2025 compared to the levels observed in 1991. This acknowledgement highlights how urgently the country must switch to renewable energy to reduce the negative environmental effects of traditional energy sources and move toward a more sustainable and prosperous future.

Solid biofuels, commonly referred to as biomass, encompass materials like wood chips, agricultural residues, and forest residues. Biomass stands out as a renewable energy source, recognized for its carbon-neutral attributes (Demirbas et al. 2009). Globally, biomass holds the fourth position among energy resources, contributing around 14% to the world's energy requirements. In developing nations, it assumes even greater significance, meeting 35% of their energy needs (Hall et al. 1992).

Carbon (C), hydrogen (H₂), oxygen (O₂), nitrogen (N₂), Sulfur (S), and a few inorganic elements make up biomass. Biomass possesses a lower heating value, ranging from 12 to 16 MJ/kg, characterized by a higher percentage of oxygen and a lower percentage of carbon content (Mukunda et al. 1994; Jain et al. 1997; Parikh et al. 1989). By physico-chemical, biochemical, and thermo-chemical processes, the chemical energy contained in biofuels can be transformed into a variety of usable forms, including mechanical, electrical, and thermal energy. Technologies like co-generation, which combines a boiler and steam turbine, and biomass gasification combined with

Figure 1a. An illustration of a downdraft gasifier schematic.

an internal combustion engine are viable options for producing electricity from biomass. These technologies represent promising avenues for harnessing the energy latent in biomass, paving the way for sustainable and diverse energy solutions. A biomass gasification system has the capacity to produce power up to less than 1MW, characterized by a favourable cost ratio. Ongoing research efforts worldwide are actively focused on enhancing the system's design, improving conversion efficiency, and optimizing various operating parameters. This global commitment to research underscores the continuous pursuit of advancements in biomass gasification technology for more efficient and cost-effective power generation.

1.1 Downdraft Gasifier

The gasification process primarily follows two routes: the biochemical route and the thermo-chemical route, both instrumental in converting biomass into producer gas (Damartzis et al. 2010). The critical chemical processes occurring in downdraft gasifiers are like drying, Pyrolysis, Combustion and gasification and its schematic diagram depicting different zones is presented in Figure 1. In co-current gasifiers, both the biomass feed and the gas stream travel in parallel directions. These gasifiers can be categorized into two distinct types: those featuring a throat design, which incorporates a choke plate, and those characterized by an open core design. Throat-type gasifiers are typically utilized for biomass fuels with minimal ash content and uniform sizes. On the other hand, open core gasifiers exhibit greater tolerance to variations in fuel properties such as moisture level, size, and ash content.

The dried feedstock undergoes further descent, during which the volatile matter contained within it undergoes devolatilization upon entry into the pyrolysis zone, where temperatures range from 250 to 550 °C. This stage yields volatile gases such as CO, CO₂, CH₄, H₂, and tar, along with char and water vapor. Subsequently, the injected air mingles with the volatile gases and char, leading to partial ignition at the combustion zone. The residual char, remaining unburnt at the combustion zone, continues its downward flow until it undergoes gasification in the reduction zone. The gas produced in the reduction zone is commonly known as producer gas, possessing a composition akin to that of the volatile gas, albeit with higher concentrations of combustible gases such as CO, CH₄, and H₂, and reduced tar content.

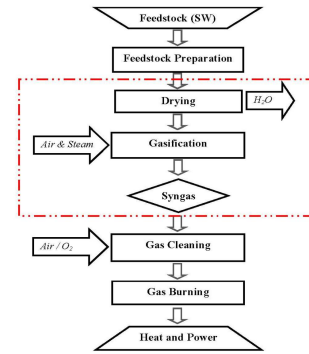

Subsequently, this enhanced quality of producer gas exits the system via the gasifier's bottom.

Producer gas is the gaseous form that biomass takes on during the solid biomass gasification process. If air is employed as the gasification mediator, then the components of this production gas are CO, CO₂, CH₄, H₂, and N₂. These ingredients include CO, CH₄, and H₂, which are combustible and, in appropriate amounts, can be used as fuel for internal combustion engines (ICEs). Internal combustion engines operate on various fuels including fossil fuels like gasoline and benzene, as well as producer gas from bio waste.

Figure 1b: Gasification process -Solid waste

However, in the transportation sector, fossil fuels contribute to around 26% of greenhouse gas emissions (GHE) (Ahmed M. Salem et al. 2023). Recently, producer gas has gained attention for its use in meeting stringent global engine emissions regulations due to its lower emissions of CO₂, SO_x, and NO_x (Baccioli et al., 2021). Moreover, producer gas can be generated from renewable sources, making it a sustainable fuel choice. It enhances system efficiency, diminishes greenhouse gas (GHG) emissions, and thereby significantly contributes to sustainable development (Arefin MA et al., 2020).

Utilizing hot producer gas from a downdraft gasifier in a dual fuel engine power plant would likely lead to decreased overall efficiency. This is primarily because cooler gas is required to enhance the volumetric efficiency of the engine. However, despite this drawback, downdraft gasifiers remain suitable for remote small-scale power generation employing internal combustion (I.C.) engines, owing to their inherent advantages such as low tar content in the product gas and their modular design. Formation of tar and total particulate matter (TPM) are observed to be major hurdles when producer gas is used in engine applications. Therefore generation of producer gas should be free from tar and TPM is essential in employing producer gas for engine application.

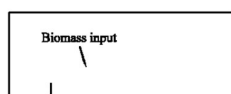

The objective of the present work is to design and develop a down draft double throat gasifier with two air supply stages that uses Prosopis Juliflora wood (Karuvellam wood) as a feed stock to generate tar free producer gas, which helps to run the IC Engine. A comprehensive analysis was conducted to examine the engine's performance when operating with producer gas as opposed to diesel fuel. Various

characteristics such as indicated thermal efficiency, total fuel consumption, diesel replacement, combustion behavior, and emissions were carefully observed and analyzed.

2 EXPERIMENTAL SETUP OF DOWNDRAFT GASIFIER WITH IC ENGINE SYSTEM

A maximum feed rate of 12.5 kg of Prosopis Juli flora wood per hour is needed to run a 10-kilowatt diesel engine. The diesel engine runs on producer gas that is taken out of the gasifier's outlet pipe; hence low tar concentration is necessary for best results. In the downdraft gasifier system, an evaluation of the double-throat gasifier with a two-air

supply approach scheme is essential to achieving a lower tar content in the producing gas. Because of the water constraint and the need to prevent direct releases of tar and particulate-contaminated water, the production gas requires cooling and dry cleaning.

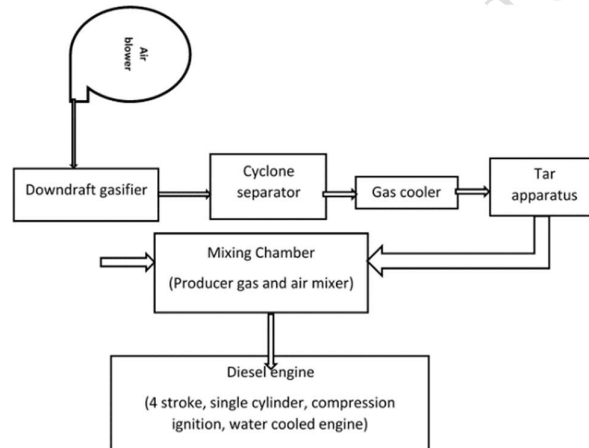

Figure 2. Flow chart for gasifier and engine system

Table 1. Specifications of Downdraft gasifier and Engine system

Gasifier			
Type	Downdraft ,two air stages at pyrolysis and combustion zone and double throat formed by convergent and divergent part.		
Hopper Diameter	680 mm	Diameter of throat	68mm
Total Height	2030 mm	Max.wood feed rate	10-15 kg/hr.
Grate	Fixed grate	Mode	Downdraft
Capacity		Hopper capacity	40-50 kg
Internal combustion Engine			
Type	4 stroke, direct injection, water cooled, diesel.	Rated RPM	1500
Compression ratio	15.8:1	SFC	245 g/kWh

Bore diameter	102 mm	Clearance volume	60.7 CC
Rated output	10 kWe	Piston	Aluminum alloy
Stroke length	110 mm	Alternator	Self-excited,1Q,5kvA

2.1 GASIFICATION SYSTEM

2.1.2 TWO STAGE AIR SUPPLY DOUBLE THROAT GASIFIER

The construction material for the gasifier reactor is steel, which is arranged in a cylindrical shape with dimensions of 500 mm in diameter and 2030 mm from the grate level. The reactor's upper section is shaped like a conical feedstock hopper, standing 700 mm tall and having a top diameter of 680 mm. This gasifier runs in a dual-stage air configuration in the pyrolysis and combustion zones. It is intended for batch loading gravity downdraft mode and can load between 10 and 15 kg of *Prosopis Juliflora* wood. The Downdraught gasifier has a double throat made up of divergent and convergent parts, and it can produce 10 kW of electricity. To reduce heat loss at the throat areas of the combustion chamber, the cylindrical reactor—which plays a critical role in this process—is coated with CUMI M45 (45% alumina) castable material. Three stages in the pyrolysis zone and above the first throat are covered by the air supply, which is positioned radially and creates a swirling motion to aid in preheating the wood. There is a pressure differential because the reactor and throat are angled at 60 degrees. It is noteworthy that the throat has three 8 mm diameter nozzles for air injection in the combustion zone and a 63 mm diameter.

A system for collecting tar at the bottom of the water bath below the grate level is built into the design of the gasifier. The engine cannot generate and provide the necessary amount of gas on its own because of the intricacy of the producer gas flow channel and the ensuing high resistance to gas flow. To counter this, a blower is positioned upstream of the gasifier in

a calculated way to overcome pressure decreases and increase the amount of producing gas that is admitted to the engine. As a result, positive pressure is applied throughout the entire gasification system. The producer gas is gathered at the center of the reactor and linked to a 10 HP water-cooled Kirloskar single-cylinder internal combustion engine. The engine is also connected to an alternator and load bank. Figure 3 carefully illustrates the two-stage double-throat downdraught gasifier's complex configuration. As shown in Figure 4, this gasifier is meticulously coupled to a water cooler and cyclone separator via a 50 mm diameter galvanized iron pipe. In addition, the system includes air supply blowers with valve configurations. To prevent any possible leakage of producer gas from the gasifier system, a water seal arrangement is strategically used at the base.



Figure 3: Fabrication setup of gasifier system

2.1.3 DIESEL ENGINE SYSTEM

Figure 4 depicts a linear schematic representation of the elaborate experimental and instrumental setup designed for evaluating the Internal Combustion (I.C.) system. Engine's performance using *Prosopis Juliflora* wood producing gas. In the meantime, Table 1 contains a thorough description of the engine's specs.

In this study, given that the engine runs on two fuels, the engine and air filter are connected in a complex way through the mixing chamber. The double-throat gasifier system and the engine system are connected through this chamber. Its main purpose is to combine the engine air that is pulled through the air filter with the producer gas that is

released from the gasifier. The engine is then fed the resulting mixture of producing gas and air. Made of mild steel (MS), the mixing chamber has carefully designed features to mix and control the amount of air and producer gas that enters the engine. Before the air and producer gas are fed into the

engine, they must be well mixed for the best possible combustion inside the cylinder. Figures 5 and 6 show a graphic representation of the engine system as a whole and the mixing chamber, respectively

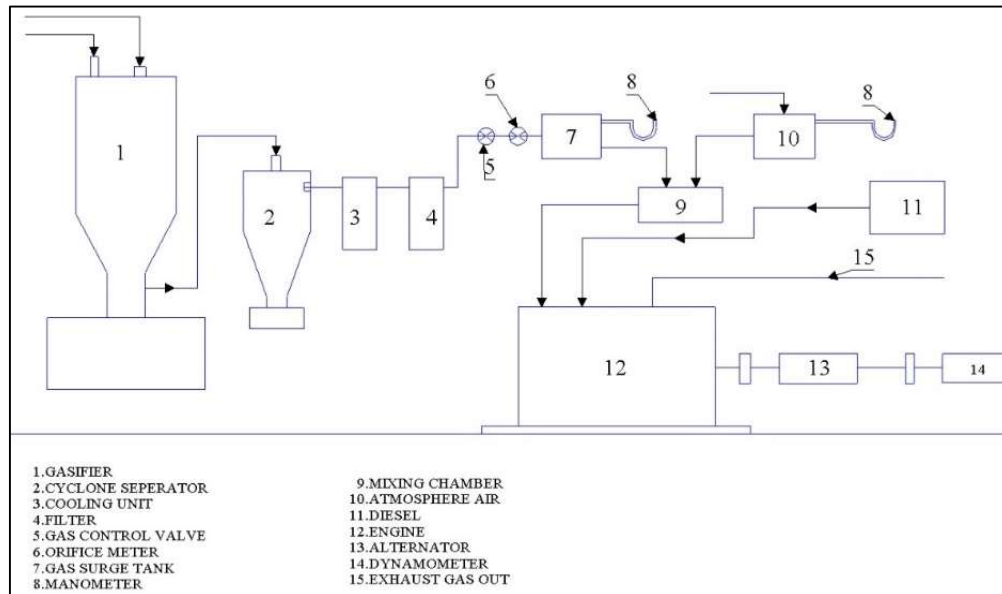

Figure 4: Experimental and Instrumental setup

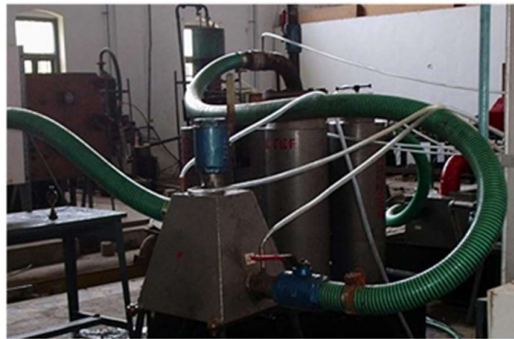

Figure 5 : Mixing chamber



Figure 6a: Engine System

3. EXPERIMENTAL APPROACH FOR GASIFIER AND ENGINE SYSTEM

Prosopis Juliflora wood is the feedstock used in this experimental study; it has a bulk density of about 300 kg/m³. The wood is ready in the shape of cubes that are roughly 40 mm by 40 mm by 30 mm. The experimental procedure is started by loading the wooden cubes into the reactor at the feedstock hopper. There are two sections to the

experimental investigation. A performance analysis of the double-throat single-stage and two-stage air and air-supply gasification techniques is carried out in the first step. Finding the ideal combination of air flow for the gasifier system is the goal. In experimental experiments, the most efficient combinations of primary and secondary air flow rates are

found by keeping the overall air flow rate between 16, 20, and 25 Nm³/hr. Table 2 shows how the lower heating value (LHV) of the generated gas is analyzed to determine the optimal position.

The secondary air supply is adjusted between 40% and 80% for a constant initial primary air supply of 16, 20, and 25 Nm³/hr, while preserving an equivalency ratio of 0.25, 0.3, and 0.4 in every scenario. Internal Combustion (IC) engines use the gas produced by the gasifier to partially replace diesel

fuel. An extensive investigation is carried out to comprehend the behaviour of the engine when it runs on producing gas. The performance characteristics of a diesel engine, which include metrics like suggested thermal efficiency, total fuel consumption, diesel replacement, combustion, and emissions behaviours, are carefully compared with the results. After that, these findings are examined to derive important conclusions.

3.1 BIOMASS CHARACTERISTICS

Karuvelam wood, also known as Prosopis Juliflora wood, is the fuel used in the downdraft gasifier. Abitek Testing Laboratory in Coimbatore has conducted a thorough investigation of the fuel's qualities; Table 3 records the findings of both the proximate and ultimate analysis. Remarkably, the fuel's moisture content is its main attribute. Yan et al. (2013) explained that this parameter has a substantial effect on the producer gas's quality. Wood is introduced into the downdraft gasifier setup from the top, while air travels through the nozzle in the same direction. One important aspect affecting the gasification process's overall

Figure 6b shows the experimental configuration as well as the gasifier's measurement system. The pipeline and related equipment, such as fittings and valves, as well as the gasification reactor (gasifier), cyclone, and suction blower, are all considered mechanical components. For thorough monitoring and analysis, the data collection system consists of a computer, a Data Acquisition (DAQ) device, communication devices, and a variety of measuring instruments. A temperature sensor (Type K thermocouple), a gas flow transmitter, a level transmitter, a gas flow counter, and an air flow meter (Rota meter) are among the assortment of measuring devices. Together, these tools make it easier to measure and record important characteristics precisely, which

	Unit	Test 1	Test 2	Test 3	Test 4	Test 5	Test 6	Test 7	Test 8	Test 9
AR	%	Single stage air supply (0%)			Two stage air supply (40 %)			Two stage air supply (80 %)		
First stage air flow	Nm ³ / hr	16	20	25	11.43	14.2	17.9	8.89	11.1	13.9
Second stage air flow	Nm ³ / hr	0	0	0	4.57	5.8	7.1	7.11	8.9	11.1
Total air flow	Nm ³ / hr	16	20	25	16	20	25	16	20	25
Equivalence Ratio		0.25	0.3	0.4	0.25	0.3	0.4	0.25	0.3	0.4

performance is the fuel's moisture.

is essential for assessing and comprehending the gasification process. The incorporation of these devices guarantees a resilient and all-encompassing data collection system for an exhaustive evaluation of the gasifier system's performance.

3.2 INSTRUMENTATION & PARAMETERS

MEASURED IN GASIFICATION SYSTEM

Table 2. Types of Gasification Approach

Ultimate Analysis		Proximate Analysis		
Properties	Percentage	Properties	Percentage	
C	42.2	Moisture	4.03	
H	5.01	Volatile Matter	84.64	
N	0.21	Fixed Carbon	10.23	
S	0.002	Calorific Value	4593.061	kcal/kg
O	46.52		19226.5533	kJ/kg
Ash	1.1	Others	1.1	
Others	4.958			

Table 3. Properties of ProsopisJuliflora wood

Table 4. The relative uncertainties of the instruments. The uncertainties associated with the measured parameters.

S. No	Paramaters	Measuring Instruments	Accuracy	Uncertainty
1	Gasifier air and producer gas flow rate	orifice meter with monometer	$\pm 4.1 \%$	$\pm 4.82 \%$
2	Gasifier temperature (T1,T2,T3,T4,T5)	Thermocouples (K-Type)	$\pm 0.5 \%$	$\pm 0.5 \%$
3	Gasifier surface temperature	Thermocouples (J-Type)	$\pm 0.5 \%$	$\pm 0.5 \%$
4	Producer gas temperature at gasifier outlet	Thermocouples (K-Type)	$\pm 0.5 \%$	$\pm 0.5 \%$
6	Gas composition in producer gas	Gas Analyzer	$\pm 4.4 \%$	$\pm 4.42 \%$
7	Producer gas pressure at gasifier outlet	monometer	$\pm 4.1 \%$	$\pm 4.76 \%$
8	ProsopisJuliflora wood Capacity	Weighing balance	$\pm 1 \%$	$\pm 1 \%$

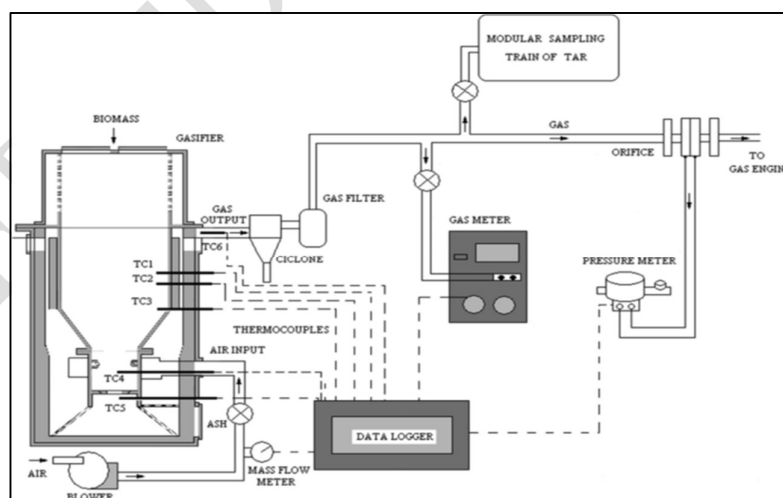

Figure 6b : Gasifier System with measuring instruments.

Rotameters 1 and 2 were utilized for measuring the air supply rate at the combustion and pyrolysis nozzles, as illustrated in Figure 6b. To compute the temperature profile along the reactor's height, six thermocouple sensors (type K) were fixed. Three thermocouples were installed: T₂ at the

combustion, T₃ at the pyrolysis, and T₁ at the gas escape point. As illustrated in Fig. 6, T₄ was positioned in between T₃ and T₅, and T₆ was lastly installed at the reactor's higher level, spaced 10 cm apart. Using a gas analyzer (NGA-2000, Fisher-Rosemount), the percentages of the gas components (CO, CO₂, CH₄, and H₂) in the producing gas were determined.

Conducting experimental measurements required a thorough examination of the inherent uncertainty within the obtained results. The total uncertainty associated with the measured values was determined using Equation (1), which factored in both random and systematic errors.

$$\sigma^2_{xi} = A^2_{xi} + P^2_{xi} \quad \text{Eq (1)}$$

Here, A_{xi} represents the systematic uncertainty of x_i , while P_{xi} denotes its random uncertainty. These uncertainties were mitigated through the process of averaging repeated measurements. Table 4 illustrates the uncertainties stemming from instrumentation.

Figure 7: Producer gas Composition Vs Equivalence Ratio

4. RESULTS AND DISCUSSION

4.1 PERFORMANCE ANALYSIS OF TWO STAGE GASIFIER WITH IC ENGINE SYSTEM

4.1.1 PRODUCER GAS COMPOSITION

Figure 8: Equivalence Ratio Vs Calorific value

The equivalent ratio is one of the key variables influencing the gasifier process under study. The final composition and calorific value of the generating producer gas for different equivalent ratio are displayed in Figure 7. At a wood equivalence ratio of 0.3, the CO and H₂ content of the producer gas declines to 18.2% and 12.6%, respectively, after peaking at 20% at an equivalency ratio of 0.18. As illustrated in Figure 8, the study indicates that the calorific value for wood reaches its maximum point at 1092 kcal/nm³ at an equivalence ratio of 0.3.

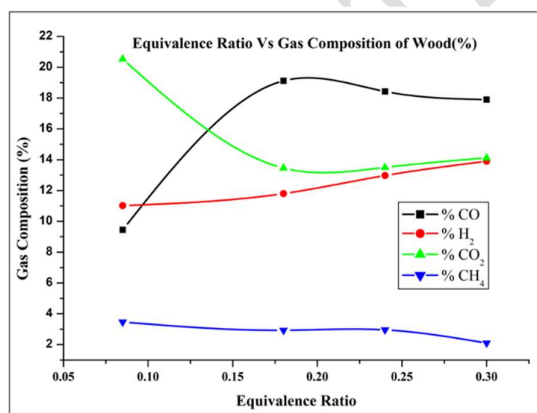

4.1.2 ENGINE PERFORMANCE ANALYSIS

Engine performance is evaluated in a relative manner based on characteristic curves that are produced by engine operating conditions. Engine power and engine efficiency are the two main aspects that are considered while evaluating engine performance. When using producer gas, several additional performance monitoring criteria were experimentally investigated and compared to diesel in addition to the overall indicated thermal efficiency.

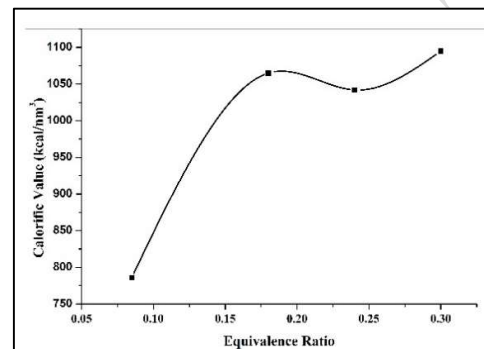

4.1.3 INDICATED THERMAL EFFICIENCY(ITE)

The engine's reported indicated thermal efficiency (ITE) with respect to engine load for both diesel and producer gas or producer gas is shown in Figure 9. It is noted that the maximum ITE achieved by diesel and producer gas mode was 50% and 30% for diesel and producer gas respectively. The reported ITE does not change as the load increases beyond 20% of engine load to maximum capacity. A maximum 40% of ITE is observed for both diesel and producer gas at 8 (80% of total load 10 kW) kW load case. But as Figure 9 illustrates, when producer gas is used instead of diesel at greater loads, the engine's estimated thermal efficiency is clearly lower than 40% for all load percentage. This difference can be explained by the producer gas's larger unburnable component content and slower flame speed.

The reduction in indicated thermal efficiency (ITE) can be attributed to the lower calorific value of producer gas, which contains a higher proportion of combusted mixture that enters the engine. Therefore, the producer gas discharged from the engine is at an elevated temperature, leading to a decrease in its density. Consequently, the mass flow rate of both the producer gas and air necessary for combustion is reduced, resulting in a decrease in the oxygen level required for complete combustion. This deficiency of oxygen in the combustion chamber is the primary cause of incomplete combustion.

4.1.4 TOTAL FUEL CONSUMPTION

As depicted in Figure 10, it is evident that the total fuel consumption (TFC) of the engine increases with the rise in load for both diesel and producer gas. The fuel consumption per hour is higher for diesel mode operation compared to producer gas. This difference is particularly notable at higher loads, where the contrast between the plots of total fuel consumption (TFC) for wood and diesel modes

becomes more pronounced. This observation unmistakably signifies the substantial replacement of diesel with producer gas mode operation. The maximum achieved diesel replacement through producer gas mode operation is 62%.

4.1.5 HEAT BALANCE ANALYSIS

Only a small portion of the energy sent to an engine which is equal to the heat value of the fuel consumed is transformed into productive activity. The heat taken away by the cooling medium and exhaust gases makes up most of the heat that is not usable. A power analyser, thermomagnetometry, water flow meter, and fuel monitoring system were used to compute the engine's energy balance under different loads, which is shown in Figure 11.

4.1.6 DIESEL REPLACEMENT IN DUAL FUEL OPERATION

Figure 12 provides the detailed information about diesel and diesel and producer gas operation of the IC engine. The engine operating parameters, including injection timing and injection pressures, were kept consistent with those of the standard diesel engine. The engine underwent gradual loading and was allowed to stabilize. Measurements were taken on the diesel consumption at different load levels. The maximum quantity of producer gas, also known as the lower limit of diesel fuel amount, was determined for each engine load based on the engine's response regarding misfires, if any, and oxygen measurements. At low loads, particularly with very high diesel replacement rates exceeding 85%, evident misfires in the exhaust were observed, indicating the threshold for substituting diesel with producer gas. Conversely, at high loads, the limiting condition was discernible based on the oxygen content in the engine exhaust. Additionally, the engine exhaust exhibited signs of being both sooty and smoky under these conditions. Furthermore, loading the engine under such circumstances compromised its ability to sustain speed and adversely affected the frequency of electricity generated. The line charts in Figure 12 show how the percentage of producer gas can replace diesel at different loads. Producer gas shows a greater degree of diesel replacement in all cases. In producer gas mode, a maximum of 61% diesel replacement has been achieved.

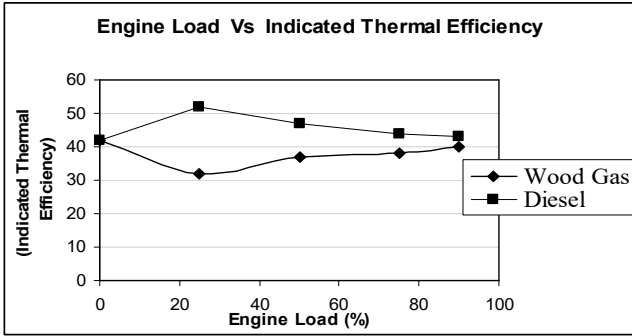

Figure 9: Engine Load Vs Indicated Thermal Efficiency

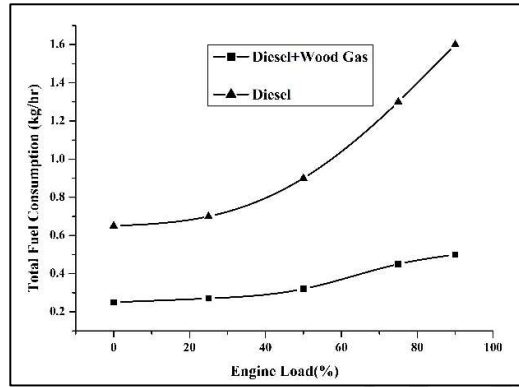

Figure 10: Engine Load Vs Total fuel consumption

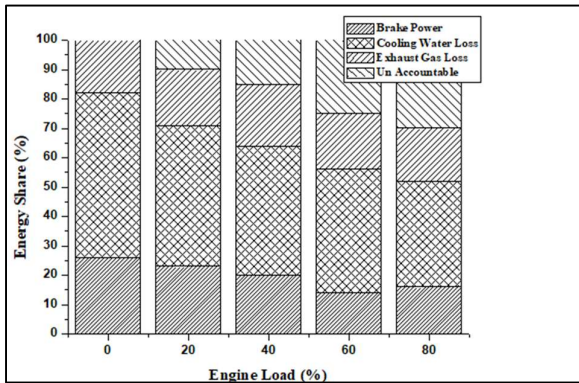

Figure 11: Heat Balance analysis on Diesel and Wood

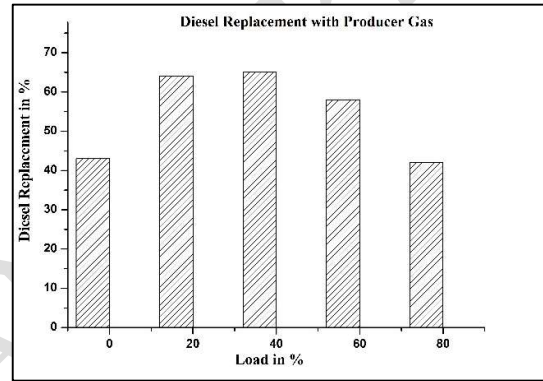

Figure 12: Diesel Replacement with producer gas

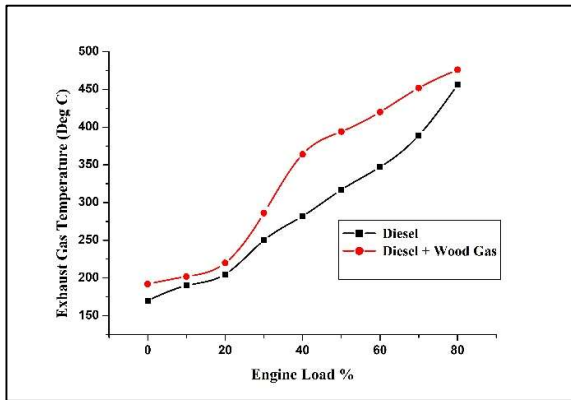

Figure 13: Exhaust Gas Temperatures Vs Engine Load

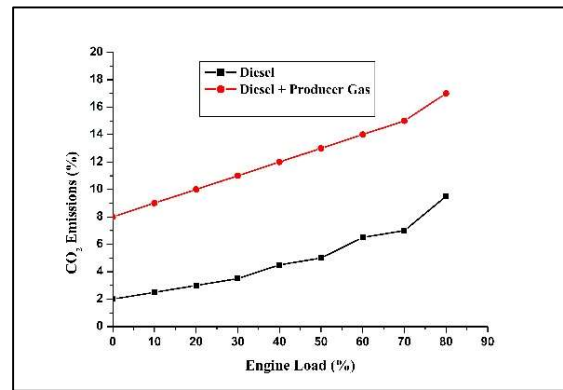

Figure 14: CO2 Emission for dual fuels and Diesel

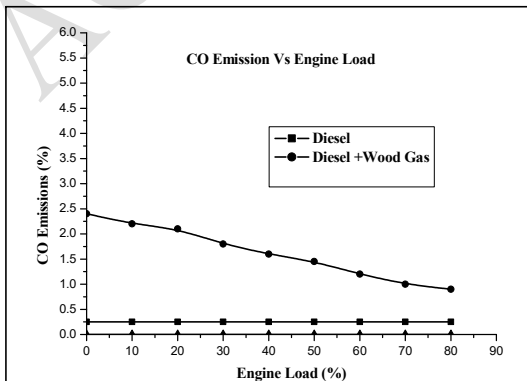

Figure 15: CO Emission for dual fuels and Diesel

4.2 ENGINE EMISSION ANALYSIS

4.2.1 EXHAUST GAS TEMPERATURE

One essential element for effective combustion is the temperature of the exhaust gas. High temperatures in the exhaust gas are a sign of slow and inefficient combustion. Based on Figure 13, we may infer that combustion mostly happens near the end of the combustion cycle since CO has a slower flame propagation speed. Exhaust temperatures in dual fuel modes are higher because of this phenomenon than in diesel mode. As contrast to diesel mode, the exhaust temperature is lower due to the higher hydrogen content in producer gas, which offsets the lower CO flame speed. Because the retained exhaust gas heats the incoming fresh air, a higher temperature of the exhaust gas results in a poorer volumetric efficiency.

4.2.2 CO₂ IN EMISSION

The amount of fuel injected into the cylinder increases in proportion to the load. As a result, Figure 14 indicates that for diesel, the CO₂ content of the exhaust gas rises as the load increases. Conversely, producer gas exhibits 11–13% CO₂, which adds to the CO₂ in flue gas. When comparing producer gas to diesel, it is shown that the former emits more CO₂. This discrepancy could be explained by the higher CO₂ content of producer gas than diesel.

4.2.3 CO IN EMISSION

There are two primary factors contributing to the formation of CO emissions. Firstly, incomplete combustion occurs due to an inadequate supply of oxygen in the combustion chamber. Secondly, poor mixture formation also plays a significant role in CO emission. Significantly higher levels of CO emissions are typically observed in diesel and producer gas mode when compared to diesel mode in figure 15. high concentration of CO emissions is due to incomplete combustion. The combination of high-temperature producer gas and air flowing into the engine diminishes the requisite oxygen level for achieving complete combustion. Consequently, this scenario fosters incomplete combustion, consequently leading to an increase in CO emissions. This is explained by the fact that producer gas has less hydrogen (H₂) than diesel, which causes the flame front to move more slowly.

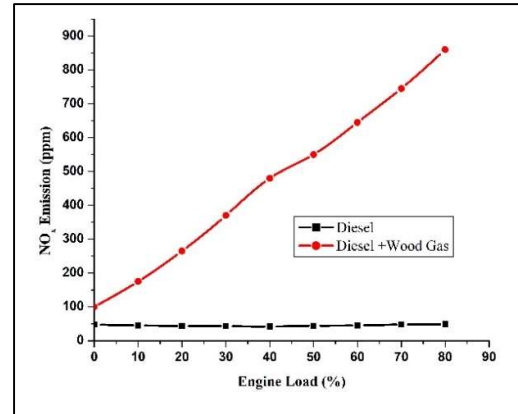

Figure 16: NO_x Emission for dual fuels and Diesel

4.2.4 OXIDES OF NITROGEN

Cylinder pressure development and NO_x emissions are strongly related. Variations in the dual fuel's composition, calorific value, and ignition temperature can have a major impact on the peak combustion temperature and, consequently, the generation of NO_x. Figure 16 shows that for all fuels, the NO_x levels rise as the load increases. Interestingly, because diesel burns more quickly at greater loads, the diesel blend has noticeably higher NO_x levels, which raises the peak temperature. Because the dual fuel has less heat content, NO_x generation is relatively low. Furthermore, more than 50% of the producer gas used to partially replace diesel is comprised of inert, which lowers the combustion temperature and reduces NO_x emissions.

4.3 COMBUSTION ANALYSIS

An examination of a fuel's combustion properties is used to determine its convertibility. The fuel is used more efficiently overall and is easier to adjust to higher combustion settings. Piezoelectric sensor, charge amplifier, crank angle encoder, and DSO were used to collect combustion characteristics for different load scenarios, including pressure and heat release rate.

4.3.1 VARIATION OF PEAK PRESSURE WITH LOAD

For both the diesel and wood modes, the pressure buildup in the engine with each minute inclination of the crank angle has been examined. Figure 17 shows the pressure versus crank angle for

different loads. Diesel has a greater peak pressure value, while producer gas mode comes in second. Dual fuels decreased calorific value, poor vaporization, and sluggish combustion may be the cause of this. Furthermore, during the first part of the compression stroke, the exhaust pressure is seen to be marginally greater than the cylinder pressure

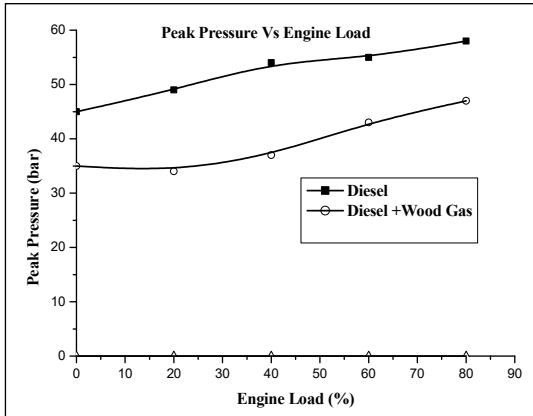

Figure 17: Variations of Peak Pressure with Engine Load

4.3.2 INDICATED MEAN EFFECTIVE PRESSURE (IMEP)

This makes it easier to compute indicated power since a continuous pressure variation over the course of the cycle may be represented as an average pressure for one cycle. Mean effective pressure (IMEP) is the term used to describe this average pressure. The engine's IMEP for each of the three fuels is shown in Figure 18 in proportion to brake power. As the load increases, the IMEP rises as well. The engine's IMEP in diesel mode was found to be just slightly higher than in producer gas mode, suggesting that the engine was operating at a derated level in dual fuel mode.

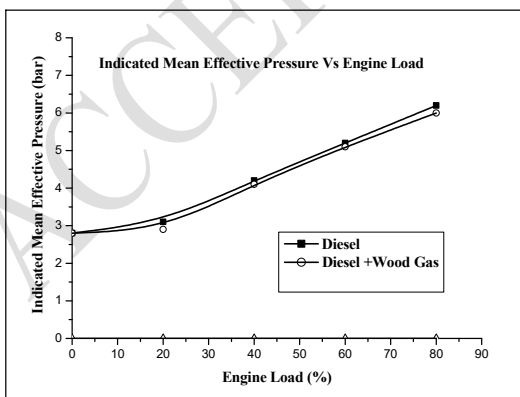

Figure 18: Indicated Mean Effective Pressure with Engine Load

4.3.3 CUMULATIVE HEAT RELEASE RATE (CHRR)

The net heat released from the start of the cycle to any given point in crank angle is represented by the Cumulative Heat Release Rate (CHRR), which is a measure of the energy used for a certain power output. Figure 19 suggests that, at the end of the cycle, the CHRR for the Producer gas mode is lower than for standard diesel fuel. This is probably because producer gas burns more slowly and has a lower calorific value. Furthermore, the maximum CHRR increases with increasing load, which is explained by the increase in overall fuel consumption. Figure 19 illustrates how the engine load affects the cumulative heat emitted at the end of the cycle. The graph shows that the cumulative heat released by both fuels increases with increasing load. Furthermore, with an 81% engine load, the producer gas maximum heat release rate curve is higher than the diesel one.

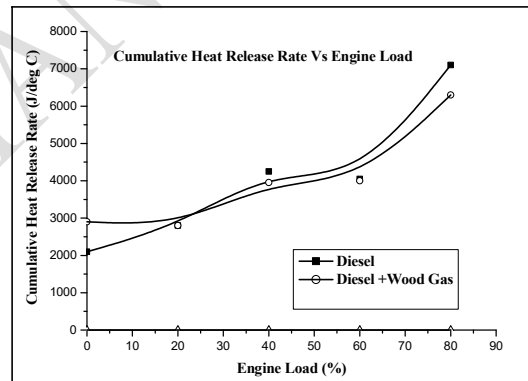

Figure 19: Cumulative Heat Release Rate with Engine Load

5. CONCLUSION

With a fuel storage hopper of 630 mm in diameter and 550 mm in height, an inventive double-throat, two-stage air supply gasifier system was created to incorporate biomass gasification technology into IC Engine operations. The gasification zone measures 150 mm in the upper and 250 mm in the lower dimensions, and it has a 70 mm throat diameter. Three 45 mm-diameter nozzles are used to deliver air to the combustion zone.

According to the findings of a thorough experimental research, diesel operation uses more fuel per hour than producer gas operation does for

the 10 kW Downdraft double-throated gasifier with IC Engine. It is found that the equivalency ratio is important for downdraft gasification and diesel substitution in IC engines under the experimental conditions that were used. According to the analysis, 1092 kcal/nm³ and 0.3 for the equivalency ratio and calorific value are the ideal operating points. In producer gas mode, the gasifier performs satisfactorily and produces less tar than diesel. From combustion study, it can be concluded that the engine operates smoothly when using two fuels. Producer gas mode shows a 62% diesel substitution at optimal loading. Because of restrictions on exhaust emissions and reduced diesel replacement, it is not recommended to run the engine in dual fuel mode at lower loads. In comparison to the diesel-based twin engine system, the producer gas-based dual engine system shows reduced emissions of CO₂, O₂, NO_x and hydrocarbons

6. REFERENCES

- Chowdhury R, Bhattacharya P and Chakravarty (1994). Modelling and simulation of a downdraft rice husk gasifier. *International journal of energy research* vol 18 pp 581-594
- Das DK, Dash SP and Ghosal MK (2011). Performance study of a diesel engine by using producer gas from selected agricultural residues on dual fuel mode of diesel-cum-producer gas. *Sweden World Renewable Energy Congress* pp 3541-8
- Dasappa S, Paul PJ, Mukunda HS, Rajan NKS, Sridhar G and Sridhar HV (2004). Biomass gasification technology e a route to meet energy needs. *Current Science* vol 87 pp 908-16
- Demirbas A (2009). Political, economic and environmental impacts of biofuels: A review. *Applied Energy* vol 86 pp S108-S117
- Gosh S, Das TK and Jash T (2004). Sustainability of decentralized wood fuel-based power plant: an experience in India. *Energy* vol 29 pp 155-66
- Hasler P, Nussabaumer Th (1999). Gas cleaning for IC engine applications from fixed bed biomass gasification. *Biomass Bioenergy* vol 16 pp 385-95
- Jain BC (2000). commercializing biomass gasifiers: Indian experience. *Energy Sustain Development* vol 4 pp 72-82
- Karuppaswamy M, Gnanavel R, Kumar S and Haridasan TM (1993). Recent advances in biomass gasification and combustion. *Bangalore India Interline Publishing*
- McKendry P (2002). Energy production from biomass (part 3) Gasification technologies. *Bioresource Technology* vol 83 pp 55-63
- Mukunda HS, Dasappa S, Paul PJ, Rajan NKS and Shrinivasa U (1994). Gasifiers and combustors for biomass-technology and field studies. *Energy for Sustainable Development: J Int Energy Initiative 1* pp 27-38
- Parikh PP, Bhawe AG, Kapse DK and Kantha Shashi (1989). Study of thermal and emission performance of small gasifier-dual fuel engine systems. *Biomass* vol 19 pp 75-97
- Rathore NS, Panwar NL, Vijay and ChiplunkarY (2009). Design and techno-economic evaluation of biomass gasifier for industrial thermal applications. *African Journal Environmental Science technology* vol 3(1) pp-1-12
- Reed TB and Das A (1988). Handbook of biomass downdraft gasifier engine system. *Golden, CO SERI*
- Stassen HE (1995). Small-scale biomass gasifiers for heat and power: a global review. *Washington World Bank*
- Stassen HE UNDP/WB (1993). small scale biomass gasifier monitoring report. Vol I *The Netherlands Biomass Technology Group University of Twente*
- Varshney R, Bhagoria JL and Mehta CR (2010). Small scale biomass gasification technology In India e an overview. *Journal of Engineering Science Management Education* 3:33-40
- Ahmed M Salem Recycling exhaust emissions of internal combustion engines within the gasification systems: Performance and analysis. *Fuel*. 346 2023 Article 128297
- Baccioli A, Liponi A, Milewski J, Szczy'śniak A, Desideri U Hybridization of an internal combustion engine with a molten carbonate fuel cell for marine applications. *Appl Energy* 2021;298:117192
- Arefin MA, Nabi MN, Akram MW, Islam MT, Chowdhury MDW A Review on Liquefied Natural Gas as Fuels for Dual Fuel Engines: Opportunities, Challenges and Responses. *Energies* 2020;13(22):6127

Michael J Greencorn, S David Jackson, Justin SJJ Hargreaves, Souvik Datta, Manosh C Paul Thermodynamic limitations to direct CO₂ utilisation within a small-scale integrated biomass power cycle. *Energ Conver Management* 269 (1) (October 2022) Article 116144

Debargha Banerjee, Debasish Das, Uddipta Ghosh Biomass Energy Potential in India: A Review.

International Journal of Engineering Research technology and 9(11):42-45,2021

International energy agency, Net Zero by 2050 A Roadmap for the Global Energy Sector bioenergy review report chapter 2 *Environmental sustainability 2023*

ACCEPTED MANUSCRIPT

Global NEST Journal
Reply for reviewers 1 Comments
Journal Name : Global NEST Journal.

Journal Paper Title: Performance Analysis of Gasification Coupled with IC Engine for Emission Control : Enhancing Environmental Sustainability
Name of the Author : Dr. S. Sivakumar
Affiliation of the PI: Assistant Professor – III, Dept of Mechanical Engineering,
Kumaraguru College of Technology, Saravanampatti, Coimbatore – 641 049

No	Question	Comments	Reply
1.	Name of the Reviewer	Reviewer1	
2.	Biomass Gasifier is	Small letter no need to capitalize	Changed to small letter
3.	equivalency		Changed to equivalence ratio
4.	(CO, H ₂)	Subscript, and please review all subscripts accordingly	The subscript notation throughout the journal paper has been altered.
5.	Kcal/nm ³	Capital letter Nm ³ , and the 3 should be superscript	
6.	a	and a	
7.	Chopra et al.	Please review the journal guidelines in citations	Modified based on journal guidelines chopra et al. (2007)
8.	500 kW	Review this number please, as there are some industrial scale units with >1MW capacity	less than 1MW,
9.	TPM	Please define	
10.	In this study, a closed-top downdraft gasifier system is designed, developed, and fabricated based on the properties of Prosopis Juliflora wood obtained		

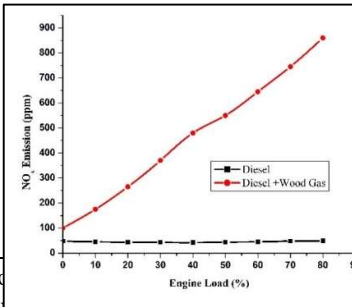
	through ultimate and proximate analyses. To integrate biomass gasification technology into internal combustion engine (IC Engine) operations, an innovative double-throat, two-stage air supply gasifier system is designed																																
11.	A maximum feed rate of 12.5	Why using two different fonts 10, and 12???																															
12.	analyses																																
13.	H ₂ ,O ₂		H ₂ O																														
14.	It has been discovered that when engine load increases, the amount of carbon monoxide (CO) in engine exhaust decreases. When comparing wood gas exhaust to diesel exhaust, the former always shows greater CO levels at all loads. This is explained by the fact that wood gas has less hydrogen (H ₂) than diesel, which causes the flame front to move more slowly. A higher CO content is suggested by the curve in Figure 15 for lighter weights.	All these discussions need to be well-elaborated and explained!!!!	There are two primary factors contributing to the formation of CO emissions. Firstly, incomplete combustion occurs due to an inadequate supply of oxygen in the combustion chamber. Secondly, poor mixture formation also plays a significant role in CO emission. Significantly higher levels of CO emissions are typically observed in diesel and wood gas mode when compared to diesel mode in figure 15. high concentration of CO emissions is due to incomplete combustion. The combination of high-temperature producer gas and air flowing into the engine diminishes the requisite oxygen level for achieving complete combustion. Consequently, this scenario fosters incomplete combustion, consequently leading to an increase in CO emissions. This is explained by the fact that wood gas has less hydrogen (H ₂) than diesel, which causes the flame front to move more slowly																														
15	Figure 16	What is unit of NO _x , what is meant by %, did you mean ppm???	NO _x unit is PPM, Graph is modified based reviewers comments.  <table border="1"> <caption>NO_x Emission (ppm) vs Engine Load (%)</caption> <thead> <tr> <th>Engine Load (%)</th> <th>Diesel (ppm)</th> <th>Diesel + Wood Gas (ppm)</th> </tr> </thead> <tbody> <tr><td>0</td><td>50</td><td>100</td></tr> <tr><td>10</td><td>50</td><td>150</td></tr> <tr><td>20</td><td>50</td><td>250</td></tr> <tr><td>30</td><td>50</td><td>350</td></tr> <tr><td>40</td><td>50</td><td>450</td></tr> <tr><td>50</td><td>50</td><td>550</td></tr> <tr><td>60</td><td>50</td><td>650</td></tr> <tr><td>70</td><td>50</td><td>750</td></tr> <tr><td>80</td><td>50</td><td>850</td></tr> </tbody> </table>	Engine Load (%)	Diesel (ppm)	Diesel + Wood Gas (ppm)	0	50	100	10	50	150	20	50	250	30	50	350	40	50	450	50	50	550	60	50	650	70	50	750	80	50	850
Engine Load (%)	Diesel (ppm)	Diesel + Wood Gas (ppm)																															
0	50	100																															
10	50	150																															
20	50	250																															
30	50	350																															
40	50	450																															
50	50	550																															
60	50	650																															
70	50	750																															
80	50	850																															
16	REFERENCES	Why there are no recent ref, the earliest here at 2011?	The follow on reviewer's suggestions.																														

		<p>Please see,</p> <p>1- Recycling exhaust emissions of internal combustion engines within the gasification systems: performance and analysis</p> <p>Fuel, 346C (2023), Article 128297</p> <p>2- Thermodynamic limitations to direct CO2 utilisation within a small-scale integrated biomass power cycle</p> <p>Energ Conver Manage, 269 (1) (October 2022), Article 116144</p>	<p>Ahmed M. Salem ,Recycling exhaust emissions of internal combustion engines within the gasification systems: Performance and analysis Ahmed M. Salem Original draft, Fuel, 346; 2023 ,Article 128297</p> <p>Baccioli A, Liponi A, Milewski J, Szczęśniak A, Desideri U. Hybridization of an internal combustion engine with a molten carbonate fuel cell for marine applications. Appl Energy 2021;298:117192.</p> <p>Arefin MA, Nabi MN, Akram MW, Islam MT, Chowdhury MDW. A Review on Liquefied Natural Gas as Fuels for Dual Fuel Engines: Opportunities, Challenges and Responses. Energies 2020;13(22):6127.</p> <p>Michael J. Greencorn , S. David Jackson, Justin J. Hargreaves , Souvik Datta, Manosh C. Paul,Thermodynamic limitations to direct CO2 utilisation within a small-scale integrated biomass power cycle Energ Conver Management, 269 (1) (October 2022), Article 116144</p>
17	<p>Jain, BC 2000, 'commercializing biomass gasifiers: Indian experience'. Energy Sustain Development, vol. 4, pp. 72-82.</p> <p>Jain, BC 2000, 'commercializing biomass gasifiers: Indian experience'. Energy Sustain Development, vol. 4, pp. 72-82.</p>	repeated	One reference is removed

Global NEST Journal

Reply for reviewers 2 Comments

Journal Name : Global NEST Journal.

Journal Paper Title: Performance Analysis of Gasification Coupled with IC Engine for Emission Control : Enhancing Environmental Sustainability
Name of the Author : Dr. S. Sivakumar
Affiliation of the PI: Assistant Professor – III, Dept of Mechanical Engineering, Kumaraguru College of Technology, Saravanampatti, Coimbatore – 641 049

No.	Comments	Reply
1	Provide concise information in the abstract so as not to exceed the 200-word limit, according to the format of the manuscript	The abstract was modified to adhere to the journal manuscript format. (Word limit within 200 words only)
2	Introduction: Update references to assess energy consumption and the role played by biomass in India. Include a short literature review on similar studies	Modified based on reviewers' comments
3	Section 1.1: avoid many repetitions of “downdraft gasifier” and provide a more technical and general description of the gasification process in the selected reactor. Explain the reasons for your choice.	<p>Modified based on reviewers' comments.</p> <p>The gasification process primarily follows two routes: the biochemical route and the thermo-chemical route, both instrumental in converting biomass into producer gas (Damartzis et al. 2010). The critical chemical processes occurring in downdraft gasifiers are like drying, Pyrolysis, Combustion and gasification and its schematic diagram depicting different zones is presented in Figure 1. In co-current gasifiers, both the biomass feed and the gas stream travel in parallel directions. These gasifiers can be categorized into two distinct types: those featuring a throat design, which incorporates a choke plate, and those characterized by an open core design. Throat-type gasifiers are typically utilized for biomass fuels with minimal ash content and uniform sizes. On the other hand, open core gasifiers exhibit greater tolerance to variations in fuel properties such as moisture level, size, and ash content.</p> <p>The dried feedstock undergoes further descent, during which the volatile matter contained within it undergoes devolatilization upon entry into the pyrolysis zone, where temperatures range from 250 to 550 °C. This stage yields volatile gases such as CO, CO₂, CH₄, H₂, and tar, along with char and water vapor. Subsequently, the injected air mingles with the volatile gases and char, leading to partial ignition at the combustion zone. The residual char, remaining unburnt at the combustion zone, continues its downward flow until it undergoes gasification in the reduction zone. The gas produced in the reduction zone is commonly known as producer gas, possessing a composition akin to that of the volatile gas, albeit with higher</p>

		<p>concentrations of combustible gases such as CO, CH₄, and H₂, and reduced tar content. Subsequently, this enhanced quality of producer gas exits the system via the gasifier's bottom production gas are CO, CO₂, CH₄, H₂, and N₂. These ingredients include CO, CH₄, and H₂, which are combustible and, in appropriate amounts, can be used as fuel for internal combustion engines (ICEs). Internal combustion engines operate on various fuels including fossil fuels like gasoline and benzene, as well as producer gas from bio waste. However, in the transportation sector, fossil fuels contribute to around 26% of greenhouse gas emissions (GHE) (Ahmed M. Salem et al. 2023). Recently, producer gas has gained attention for its use in meeting stringent global engine emissions regulations due to its lower emissions of CO₂, SO_x, and NO_x (Baccioli et al., 2021). Moreover, producer gas can be generated from renewable sources, making it a sustainable fuel choice. It enhances system efficiency, diminishes greenhouse gas (GHG) emissions, and thereby significantly contributes to sustainable development (Arefin MA et al., 2020).</p> <p>Utilizing hot producer gas from a downdraft gasifier in a dual fuel engine power plant would likely lead to decreased overall efficiency. This is primarily because cooler gas is required to enhance the volumetric efficiency of the engine. However, despite this drawback, downdraft gasifiers remain suitable for remote small-scale power generation employing internal combustion (I.C.) engines, owing to their inherent advantages such as low tar content in the product gas and their modular design. Formation of tar and total particulate matter (TPM) are observed to be major hurdles when producer gas is used in engine applications. Therefore generation of producer gas should be free from tar and TPM is essential in employing producer gas for engine application</p>
4	Table 1: check the gasifier information: the capacity of 10 kWe relates to the engine	Modified based on reviewer's comments
5	Measurements should be complemented with uncertainty analysis	<p>The following uncertainty details included with in journal paper based on reviewers comments:</p> <p>values was determined using Equation (1), which factored in both random and systematic errors.</p> $\sigma_{2 \text{ xi}} = A^2 \text{ xi} + P^2 \text{ xi} \quad \text{Eq (1)}$ <p>Here, Axi represents the systematic uncertainty of xi, while Pxi denotes its random uncertainty. These uncertainties were mitigated through the process of averaging repeated measurements. Table 4 illustrates the uncertainties stemming from instrumentation.</p>

6	Improve the quality of all graphs (figures 8-19).	quality of all graphs (figures 8-19) are improved with DPI Resolution 600 ,Colour depth of true colour quality.
5	Include comments on engine regulation at part load to better explain Fig. 9.	<p>Modified based on reviewers' comments.</p> <p>The engine's reported indicated thermal efficiency (ITE) with respect to engine load for both diesel and wood gas or producer gas is shown in Figure 9. It is noted that the maximum ITE achieved by diesel and wood gas mode was 50% and 30% for diesel and wood gas respectively. the reported ITE does not change as the load increases beyond 20 % of engine load to maximum capacity. A maximum 40 % of ITE is observed for both diesel and wood gas at 8 (80 % of total load 10 kW) kW load case. But as Figure 9 illustrates, when wood gas is used instead of diesel at greater loads, the engine's estimated thermal efficiency is clearly lower than 40 % for all load percentage. This difference can be explained by the producer gas's larger unburnable component content and slower flame speed.</p> <p>The reduction in indicated thermal efficiency (ITE) can be attributed to the lower calorific value of producer gas, which contains a higher proportion of combusted mixture that enters the engine. Therefore, the producer gas discharged from the engine is at an elevated temperature, leading to a decrease in its density. Consequently, the mass flow rate of both the producer gas and air necessary for combustion is reduced, resulting in a decrease in the oxygen level required for complete combustion. This deficiency of oxygen in the combustion chamber is the primary cause of incomplete combustion.</p>
6	Include comments to better explain the trend shown in Fig. 12	<p>Modified based on reviewers' comments.</p> <p>Figure 12 provides the detailed information about diesel and diesel and wood gas operation of the IC engine. The engine operating parameters, including injection timing and injection pressures, were kept consistent with those of the standard diesel engine. The engine underwent gradual loading and was allowed to stabilize. Measurements were taken on the diesel consumption at different load levels. The maximum quantity of producer gas, also known as the lower limit of diesel fuel amount, was determined for each engine load based on the engine's response regarding misfires, if any, and oxygen measurements. At low loads, particularly with very high diesel replacement rates exceeding 85%, evident misfires in the exhaust were observed, indicating the threshold for substituting diesel with producer gas. Conversely, at high loads, the limiting condition was discernible based on the oxygen content in the engine exhaust. Additionally, the engine exhaust exhibited signs of being both sooty and smoky under these conditions. Furthermore, loading the engine under such circumstances compromised its ability to sustain speed and adversely affected the frequency of electricity generated.</p>
7	Conclusion Mention NOx in the last paragraph.	<p>Modified based on reviewer's comments.</p> <p>In comparison to the diesel-based twin engine system, the wood gas-based dual engine system shows reduced emissions of CO₂, O₂, NO_x and hydrocarbons</p>

ACCEPTED MANUSCRIPT

ACCEPTED MANUSCRIPT