

Study on Eco-environmental Quality Evaluation of Rural Tourism Area Based on Factor Evaluation Method

Hui Yang

Changchun University of Finance and Economics, Changchun, Jilin, 130000, China

Correspondence should be addressed to Hui Yang: huiyang463@gmail.com

Graphical Abstract



Distribution of ecological state of rural human settlements



Distribution of local characteristics of ecological protection

Abstract: For improve the evaluation ability of eco-environmental quality in rural tourism areas, a factor evaluation method was proposed. The big data mining method is used to quantitatively evaluate different types of ecological environment and extract their features. The fuzzy clustering method is used to adaptively schedule the extracted feature quantity, and the evaluation objective function is constructed by combining the joint association rule mining and linear fitting analysis. The main indicators of tourist attractions are graded by factor evaluation method, and the ecological environment quality of tourist attractions is evaluated by objective function. A dataset consisting of 800 evaluation

samples and 1,000 training samples, which spans from July 2016 to April 2022, was used in simulation experiments performed with MATLAB and Visual C++ to verify the efficacy of the proposed method. While evaluating the quality of the eco-environment, descriptive statistical analysis shows better accuracy and balance than conventional methods. Based on the results, the proposed approach offers a confidence level greater than 91% while achieving higher evaluation levels at a lower cost. The proposed method is reliable and cost-effective, as evidenced by life cycle cost comparisons between various improvement schemes. This is especially true given the reduced expenses associated with operation and maintenance. The method's accuracy and resilience in assessing the eco-environmental quality of rural tourism regions are highlighted by the much decreased steady-state errors and average risk values found in the analysis of experimental data.

Keywords: human settlements; Ecological adaptation adjustment; Rural tourist areas; eco-environment; quality evaluation

1. Introduction

The development of rural tourism areas is relatively mature, and theories and ideas of eco-environment and other related disciplines have been integrated into the planning field of human settlements, constantly improving the connotation and extension of the planning discipline of rural tourism areas of human settlements, and forming many interdisciplinary disciplines such as urban ecology and architectural ecology. On the other hand, the disadvantages of urban-rural dual contradiction and unbalanced development are also reflected in the disciplines related to ecological planning and construction of human settlements. As the development of rural planning discipline is relatively backward, it is even more necessary to know and understand the process and law of rural development under the framework of the first-level discipline of urban and rural planning, constantly enrich its connotation and extension of ecological theory, and construct and improve its planning theory and practice system.

Most of the eco-environment quality assessment methods are realized by combining mathematical model construction and statistical regression analysis [1-2]. Based on this, the evaluation model is constructed to realize the prediction of eco-environment quality. In addition to the above methods, parallel computing methods, PSO methods and peer analysis methods have also realized the eco-environment quality planning [3-5], and some research results have been obtained. Among them, reference [6] proposed a study on marine fishery eco-environment quality evaluation based on Two-stage Fuzzy QFD, and established a two-stage quality function deployment model by studying the evaluation process through fuzzy set analysis method. First, green development was transformed into marine ecological sustainability indicators, and then the marine ecological sustainability indicators in the matrix were transformed into ecological characteristic factors. Finally, Some suggestions on the green development of marine fishery were put forward. Reference [7] proposed a study on visual environment quality evaluation. This method studies the impact of landscape elements and landscape characteristics of urban ecological parks. Through the analysis of urban landscape architecture, a design method of urban landscape architecture based on the combination of SBE and SD is proposed. These

achievements have certain guiding significance for the construction and transformation of urban ecological parks, but there are problems such as high cost and low accuracy of evaluation. To increase evaluation precision, we aim to propose a new method based on fuzzy clustering and the factor evaluation method, that blends adaptive feature extraction with association rule mining, in contrast to traditional methods that rely on regression and mathematical models. This main contribution of this paper puts forward the eco-environment quality evaluation of rural tourism area based on factor evaluation method. On the basis of extracting the evaluation of eco-environment quality and feature extraction [8-9], the fuzzy clustering method is used to adaptively schedule the extracted feature quantity. The objective function is constructed by combining the joint association rule mining and linear fitting analysis method [10]. The factor evaluation method is used to realize the evaluation of the eco-environment quality of rural tourism areas. The proposed method solves the drawbacks of existing methods, including their poor accuracy and expensive prices, while simultaneously improving the precision of eco-environmental assessments. The work advances the approach for assessing and controlling eco-environmental quality in rural tourism areas by demonstrating, through rigorous simulation testing, the practical applicability and usefulness of the proposed model in real-world scenarios.

2. Proposed methodology

2.1. Quantitative evaluation of eco-environment quality in rural tourism

With the increase of rural construction land and the increasing amount of artificial construction [11-13], it will inevitably lead to many ecological contradictions. Therefore, there are ecological problems such as the contradiction between man and land, energy and material consumption, environmental pollution and so on in rural human settlements. This phenomenon needs to be paid attention to, and it will become one of the research fields of rural residential environment planning in the future. The quantitative index vector set of rural tourism area eco-environment quality evaluation is constructed, and the extracted evaluation characteristic quantity of rural tourism area eco-environment quality [14], and the parameter distribution model of rural tourism area eco-environment quality evaluation can be expressed as follows:

$$\begin{cases} \ddot{\varphi}_a = -(b_1 + \Delta b_1)\dot{\varphi}_a - (b_2 + \Delta b_2)\varphi_a - (b_3 + \Delta b_3)\delta_\varphi + fd_1 \\ \ddot{\psi}_a = -(b_1 + \Delta b_1)\dot{\psi}_a - (b_2 + \Delta b_2)\psi_a - (b_3 + \Delta b_3)\delta_\psi + fd_2 \\ \ddot{\gamma} = -(d_3 + \Delta d_3)\delta_\gamma + fd_3 \end{cases} \quad (1)$$

Wherein, $\varphi_a, \psi_a, \gamma$ are the classification set of eco-environment quality characteristics, $\dot{\varphi}_a, \dot{\psi}_a, \dot{\gamma}$ are the decomposition scale of eco-environment quality distribution characteristics, and $\ddot{\varphi}_a, \ddot{\psi}_a, \ddot{\gamma}$ are the redundant characteristic quantity of eco-environment quality of rural tourism areas. In this context, the term "decomposition scale" refers to the hierarchical separation of eco-environmental elements for in-depth examination, which is essential for comprehending differing effects at various scale levels. The assessment and management of environmental quality in rural tourism areas is of utmost importance. It involves a complete evaluation and strategic planning process that greatly improves the transparency of the study and facilitates the proper interpretation of its findings. The differential evolution algorithm is used to analyze the big data of the evaluation indicators, and the feature clustering and other

technologies are used to cluster the evaluation indicators ^[15-17]. The ecological environment of rural tourism destinations in China is studied by using the minimum linear programming method, as shown in:

$$\begin{cases} \ddot{\phi}_a = -b_1\dot{\phi}_a - b_2\phi_a - b_3\delta_\phi + \rho_1 \\ \ddot{\psi}_a = -b_1\dot{\psi}_a - b_2\psi_a - b_3\delta_\psi + \rho_2 \\ \ddot{\gamma} = -d_3\delta_\gamma + \rho_3 \end{cases} \quad (2)$$

Wherein, $\rho_1 = -\Delta b_1\dot{\phi}_a - \Delta b_2\phi_a - \Delta b_3\delta_\phi + fd_1$, it represents the distribution state of eco-environment quality, $\rho_2 = -\Delta b_1\dot{\psi}_a - \Delta b_2\psi_a - \Delta b_3\delta_\psi + fd_2$, which represent the characteristic quantity of joint state of eco-environment quality, and $\rho_3 = -\Delta d_3\delta_\gamma + fd_3$ is the uncertainty of eco-environment quality. The distribution vector set of evaluation indexes obtained by the correlation statistical analysis ^[18-20] is described as:

$$\ddot{\phi}_a = a_1\dot{\phi}_a + a_2\phi_a + bu + f_d \quad (3)$$

Wherein, $b > 0$ and ϕ_a are the average value, $\dot{\phi}_a$ is the inspection statistical value of eco-environment quality evaluation in rural tourism areas, u is the input of eco-environment quality evaluation system, and f_d is the additional interference item in eco-environment quality evaluation.

Using the regional correlation feature extraction method ^[21-22], the ecological environment quality of rural tourism areas was balanced and distributed, and the collinearity problem of the ecological environment quality evaluation of rural tourism areas was transformed into:

$$b^{-1}\ddot{\phi}_a - b^{-1}(a_1\dot{\phi}_a + a_2\phi_a) = u + b^{-1}f_d \quad (4)$$

Set $M = b^{-1}$, $h(\phi_a, \dot{\phi}_a) = -b^{-1}(a_1\dot{\phi}_a + a_2\phi_a)$, $d(t) = b^{-1}f_d$. By using the descriptive statistical analysis method, this paper analyzes the statistical characteristics of the evaluation of the ecological environment quality in rural tourism areas, and establishes the statistical characteristics of the statistical distribution of the evaluation of the ecological environment quality in rural tourism areas.

$$M\ddot{\phi}_a + h(\phi_a, \dot{\phi}_a) = u(t) + d(t) \quad (5)$$

Set

$$\begin{cases} e_1 = \phi_a - \phi_{ad} \\ e_2 = \dot{\phi}_a - \dot{\phi}_{ad} \end{cases} \quad (6)$$

Where in e_1 and e_2 respectively represent the joint error of eco-environment quality evaluation, $u(t)$ is the difference characteristic, and $d(t)$ is the configuration parameter of eco-environment quality, thus a quantitative index vector group is established for the evaluation of ecological environment quality. Application of association rule feature extraction method based on feedback restriction in ecological environment quality assessment ^[23-26], and the classification model of factor evaluation method is combined to cluster the characteristic information of the statistical data of eco-environment quality evaluation.

2.2. Statistical data mining

The quantization index vector set obtained above is subjected to fuzzy mining processing. The big data mining method is used to extract the evaluation features ^[27-29], and the fuzzy clustering method is used

to adaptively schedule the extracted features ^[30-32]. The statistical feature quantity obtained is:

$$\begin{cases} \dot{e}_1 = e_2 \\ \dot{e}_2 = M_n^{-1}u - M_n^{-1}h_n(\varphi_a, \dot{\varphi}_a) - \ddot{\varphi}_{ad} \end{cases} \quad (7)$$

Where in, $h_n(\varphi_a, \dot{\varphi}_a)$ is the joint characteristic value distribution in rural tourism areas, $\ddot{\varphi}_{ad}$ is the fuzzy state parameter in rural tourism areas, and M is the statistical characteristic quantity in rural tourism areas. After standard normalization of the original data, the statistical data in rural tourism areas can be regarded as a set of nonlinear statistical distribution sequences, and the sliding surface is defined as

$$s = ce_1 + e_2 \quad (8)$$

Then

$$\dot{s} = c\dot{e}_1 + \dot{e}_2 = c\dot{e}_2 + \dot{e}_2 \quad (1)$$

Set

$$\dot{s} = 0 \quad (2)$$

Wherein, c, \dot{e}_1, \dot{e}_2 respectively represent the constraint index parameters of the eco-environment quality evaluation of rural tourism areas. Using a multivariate statistical characteristic equation to describe the fitting characteristic quantity of the eco-environment quality evaluation of rural tourism areas, there are

$$\begin{aligned} & ce_2 + \dot{e}_2 \\ &= ce_2 + \ddot{\varphi}_a - \ddot{\varphi}_{ad} \\ &= ce_2 + M_n^{-1}u - M_n^{-1}h_n(\varphi_a, \dot{\varphi}_a) - \ddot{\varphi}_{ad} \\ &= 0 \end{aligned} \quad (11)$$

For a continuous statistical distribution sequence of rural tourism eco-environment quality evaluation statistics, the feature training subset $S_i (i=1,2,\dots,L)$ of rural tourism eco-environment quality evaluation statistics of each spatial solution vector satisfies the equivalent control law as follows:

$$u_{eq} = h_n(\varphi_a, \dot{\varphi}_a) + M_n \ddot{\varphi}_{ad} - M_n ce_2 \quad (3)$$

Let $x_{n+1} = \mu x_n (1 - x_n)$ be the conjugate solution of a statistical model of statistical distribution sequence in rural tourism areas. In order to avoid the influence of uncertain factors in the eco-environmental quality evaluation of rural tourism areas, the mean test model is constructed as

$$u_0 = -\text{sgn}(M_n) \bar{\rho}(t) \text{sgn}(s) \quad (4)$$

Then the statistical data of eco-environment quality evaluation in rural tourism areas are output as follows:

$$\begin{aligned} u &= u_{eq} + u_0 = h_n(\varphi_a, \dot{\varphi}_a) + M_n \ddot{\varphi}_{ad} \\ &\quad - M_n ce_2 - \text{sgn}(M_n) \bar{\rho}(t) \text{sgn}(s) \end{aligned} \quad (5)$$

Wherein, u_{eq} is the adjustment parameter of human settlements ecological adaptability, and s is the characteristic parameter. The Lyapunov function in rural tourist areas is defined as:

$$V = \frac{1}{2} s^2 \quad (6)$$

The constraint function of statistical data information vector to differential equation in rural tourist areas satisfies the (2+1)-dimensional continuous functional condition, where the constraint conditions

are:

$$\Psi_x(\omega) = \ln \Phi_x(\omega) = -\frac{1}{2} \omega^2 \sigma^2 \quad (16)$$

Where in, $\Phi_x(\omega)$ is the fuzzy parameter of eco-environment in rural tourism areas, and σ is the factor evaluation parameter of eco-environment quality evaluation in rural tourism areas. It can be seen that the data mining model designed in this paper is stable and bounded.

2.3. Optimization of eco-environment quality evaluation model

On the basis of evaluation and feature extraction of eco-environment quality by using big data mining method, the characteristic quantity of eco-environment quality evaluation is classified and analyzed by using factor evaluation method and neural network classifier. This paper puts forward the eco-environment quality evaluation based on factor evaluation method, and constructs the quantitative index vector set of eco-environment quality evaluation in rural tourism areas. The model of factor evaluation method is shown in Figure 1.

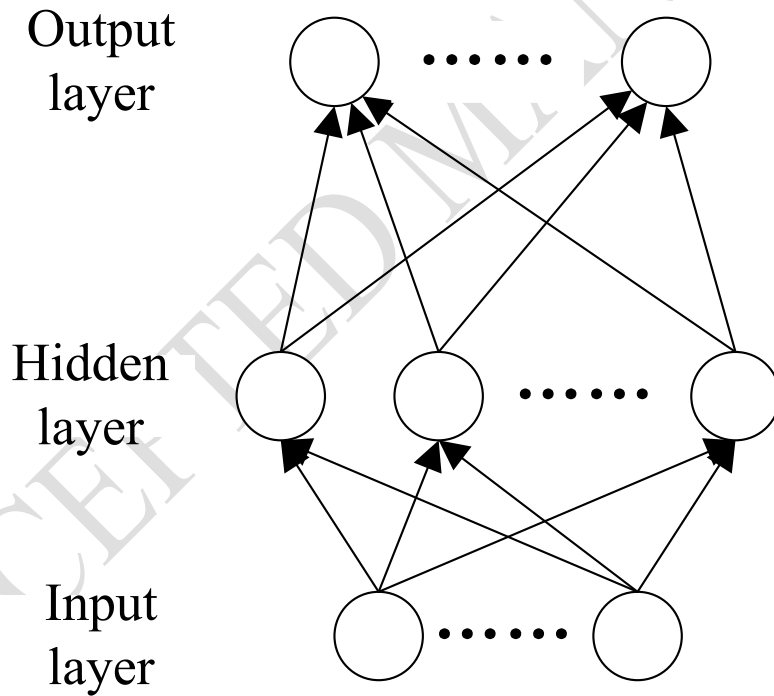

Fig. 1 Model of factor evaluation method

In the factor evaluation method model of eco-environment quality evaluation of rural tourism areas shown in Figure 1, the calculation relation of statistical characteristic quantity distribution of eco-environment quality evaluation of rural tourism areas is as follows:

$$y_j = \sum_{i=1}^n x_i * a_{ij} + \delta 1 \quad (17)$$

$$z_k = \sum_{j=1}^m y_j * b_{jk} + \delta 2 \quad (18)$$

Wherein, $x_i (i=1,2,,n)$ represents the elements in the input layer of eco-environmental quality evaluation, and n is the number of elements in the input layer of eco-environmental quality ambiguity; It indicates the weighted value from the input layer to the hidden layer in the evaluation of eco-environment quality of human settlements, and $a_{ij} (i=1,2,,n; j=1,2,,m)$ is the number of elements in the hidden layer; $b_{jk} (j=1,2,,m; k=1,2,,p)$ indicates the threshold value from the input layer to the hidden layer of eco-environment quality evaluation; Indicates the element value of the hidden layer of eco-environment quality evaluation in rural tourist areas under the adjustment of P human settlements ecological adaptability; It represents the weighted value from the hidden layer to the output layer of eco-environment quality evaluation under the adjustment of $\delta 1$'s living ecological adaptability, and $z_k (k=1,2,,p)$ is the number of elements in the hidden layer; K is the output element value for the eco-environment quality evaluation of rural tourist areas; It indicates the threshold value from the hidden layer to the output layer of eco-environment quality evaluation under the adjustment of net_j human settlements ecological adaptability.

On the basis of evaluating the dynamic trend prediction error correction of statistical data, the fuzzy weighted control method is used to analyze the evaluation statistical characteristics in the j -th neuron. The total input is equal to the output $w_{1j}, w_{2j}, \dots, w_{nj}$ of each branch connected with it, multiplied by the sum of the weights x_1, x_2, \dots, x_n respectively, and the distribution of the association rules of the eco-environment quality evaluation in rural tourism areas is as follows

$$net_j = \sum_{i=1}^n w_{ij} x_i(t), \quad i \neq j \quad (7)$$

Wherein, w_{ij} is the adaptive right of eco-environment quality in rural tourism areas, $x_i(t)$ is the characteristic parameter of eco-environment quality in rural tourism areas, and the state of BP neuron in eco-environment quality evaluation in rural tourism areas is determined by the state transition function of this neuron. The factor evaluation method and neural network classifier are used to classify and analyze the characteristic quantities, and the fuzzy weighted control of is carried out by combining univariate descriptive statistical analysis and mean test method. The next state of neurons can be generated according to its state function, and the adaptive weight of eco-environmental quality evaluation in rural tourism areas can be obtained:

$$u_j(k+1) = g(net_j - \theta_j, u_j(k)) \quad (8)$$

Wherein, θ_j is the threshold value of BP neuron for eco-environment quality evaluation of rural tourism areas, and the threshold value is set to zero in the calculation of this paper. The output of eco-environment quality evaluation neurons in rural tourism areas is determined by the output function of the neurons. Using template matching method and neuron state as independent variable, the eco-environment big data mining and feature scheduling in rural tourism areas are carried out, and the adaptive classification output of eco-environment quality evaluation statistics in rural tourism areas is obtained as follows:

$$x_j(k) = f(u_j(t)) \quad (9)$$

Wherein, $u_j(t)$ is the joint degree parameter of eco-environment quality in rural tourism areas. Here, Sigmoid function is used as the training function to detect the eco-environment in rural tourism areas, and its expression is

$$f(x) = \frac{1}{1 + e^{-x}} \quad (10)$$

Wherein, e^{-x} is the fuzzy parameter of eco-environment quality in rural tourism areas. The statistical data of eco-environment quality evaluation in rural tourism areas are dynamically predicted, and the input state variables of eco-environment quality evaluation in rural tourism areas are obtained by using factor analysis and characteristic evaluation methods at any sampling time:

$$net_i(k) = r_i(k) \quad i = 1, 2 \quad (23)$$

Wherein, $r_i(k)$ is the association rule of eco-environment in rural tourist areas of human settlements. It is assumed that the statistical data of eco-environmental quality evaluation in rural tourism areas are generated by linear correlation nonlinear statistical feature distribution series, and their respective total input values are:

$$net'_j(k) = \sum_{i=1}^2 w_{ij} x_i(k) \quad j = 1, 2, 3 \quad (11)$$

Wherein, w_{ij} is the connection weight value from the input layer to the hidden layer of the evaluation method of ecological factors; The superscript "" is the variable mark of the hidden layer of the factor evaluation method. Eco-environmental quality evaluation of rural tourism areas; the state of scale element of evaluation method of eco-environmental quality evaluation factors of rural tourism areas is as follows:

$$u'_1(k) = net'_1(k) \quad (25)$$

Wherein, $net'_1(k)$ is the eco-environment quality evaluation factor of rural tourism area, and the status of integral element of fuzzy evaluation method is obtained as follows

$$u'_2(k) = u'_2(k-1) + net'_2(k) \quad (26)$$

Wherein, $u'_2(k-1)$ is the fuzzy parameter, and $net'_2(k)$ is the iterative step of factor learning. The state of differential element of evaluation method of eco-environment quality in rural tourism areas is as follows

$$u'_3(k) = net'_3(k) + net'_3(k-1) \quad (27)$$

Eco-environmental quality evaluation of rural tourism areas Evaluation method of eco-environmental quality evaluation factors of rural tourism areas. The output of each neuron in the hidden layer is:

$$x'_j(k) = \frac{1}{1 + e^{-u'_j(k)}} \quad (j = 1, 2, 3) \quad (12)$$

Eco-environmental quality evaluation of rural tourism areas The output layer structure of the evaluation method of eco-environmental quality evaluation factors in rural tourism areas is relatively simple. Using multiple linear regression analysis method, the output of univariate statistical analysis is as follows:

$$net''(k) = \sum_{j=1}^3 w'_j x'_j(k) \quad (13)$$

Wherein, x'_j is the output value of each neuron in the hidden layer of ecological evaluation factor parameters in rural tourism areas; w'_j is the connection weight value from the hidden layer to the output layer of ecological evaluation factor parameters in rural tourism areas of human settlements. Based on the feature extraction of the feedback constraint association rules, the prediction error of the statistical data of the ecological environment quality assessment in rural tourism areas is modified. The output of the BP neural network is equal to the output of the output layer neuron, that is:

$$v(k) = x''(k) \quad (30)$$

Here, the weights from the input layer to the hidden layer of the proposed method are fixed. Note $\omega_{ij} (i=1,2; j=1,2,3)$, set the input of the evaluation method of eco-environmental quality evaluation factors in rural tourism areas as $\omega'_j (j=1,2,3)$, and the output as the estimated value of the upper bound of uncertain parameters, and there are:

$$\hat{\rho}(x, \omega) = \omega'_1 \sigma_1(\varphi_a, \dot{\varphi}_a) + \omega'_2 \sigma_2(\varphi_a, \dot{\varphi}_a) + \omega'_3 \sigma_3(\varphi_a, \dot{\varphi}_a) \quad (14)$$

Wherein, $\sigma_j(\varphi_a, \dot{\varphi}_a)$ is the output of the hidden layer of the evaluation method of eco-environment quality evaluation factors in rural tourism areas, and the classifier model is obtained as follows:

$$\begin{cases} \sigma_1(\varphi_a, \dot{\varphi}_a) = \frac{1}{1 + e^{-(\omega_{11}\varphi_a + \omega_{21}\dot{\varphi}_a)}} \\ \sigma_2(\varphi_a, \dot{\varphi}_a) = \frac{1}{1 + e^{-\int (\omega_{21}\varphi_a + \omega_{22}\dot{\varphi}_a) dt}} \\ \sigma_3(\varphi_a, \dot{\varphi}_a) = \frac{1}{1 + e^{-d(\omega_{11}\varphi_a + \omega_{21}\dot{\varphi}_a)}} \end{cases} \quad (32)$$

Therefore, the optimal weight ω_j^* of ecological evaluation factors in rural tourist areas is obtained:

$$\omega_1^* \sigma_1 + \omega_2^* \sigma_2 + \omega_3^* \sigma_3 - \bar{\rho}(t) = \varepsilon(\varphi_a, \dot{\varphi}_a) < \varepsilon_1 \quad (15)$$

The adaptive algorithm is adopted to adjust the online weights of ecological evaluation parameters of rural tourist areas, and the following values are taken:

$$\hat{\omega} = \eta |sM_n^{-1}| \sigma(\varphi_a, \dot{\varphi}_a) \quad (16)$$

$$\eta = |M_n^{-1}| (\varepsilon_0 - \varepsilon_1) > 0 \quad (17)$$

On the premise of satisfying Lyapunov stability condition, the eco-environmental quality evaluation model of rural tourism area based on factor evaluation method is stable and convergent.

3. Simulation analysis

To test the practical application performance of the algorithm in this paper, simulation experiments are carried out. Matlab 7 and Visual C++ programming were used in the experiment, and the time interval of collecting eco-environment quality evaluation statistics in rural tourism areas was from July 2016 to April 2022. The sample number of the eco-environment quality evaluation data in rural tourism areas is 800, and the training sample set is 1,000. The prediction step of in rural tourism areas is 60. See Table 1 for descriptive statistical analysis results.

Table 1 Descriptive statistical analysis results

| Data set | Contrast group 1 | Contrast group 2 | Contrast group 3 |
|--|------------------|------------------|------------------|
| Urban-rural integration process | 0.719 | 0.341 | 0.598 |
| Utilization of natural resources | 0.456 | 0.014 | 0.643 |
| Ecological parameters of rural planning and Construction | 0.650 | 0.291 | 0.420 |
| Ecological tourism planning | 0.812 | 0.084 | 0.996 |

According to the above statistical analysis results, the eco-environment quality of rural tourist areas is evaluated, and the distribution results of factor evaluation methods for evaluating characteristic quantities are shown in Figure 2- Figure 4.



Fig. 2 Distribution of ecological state of rural human settlements



Fig. 3 Distribution of local characteristics of ecological protection



Fig. 4 state distribution at social and planning levels

From the analysis of Figure 2 to Figure 4, it is known that the accuracy is better, and the balance of eco-environment quality is better. The grade output of quality evaluation is tested, as shown in Figure 5.

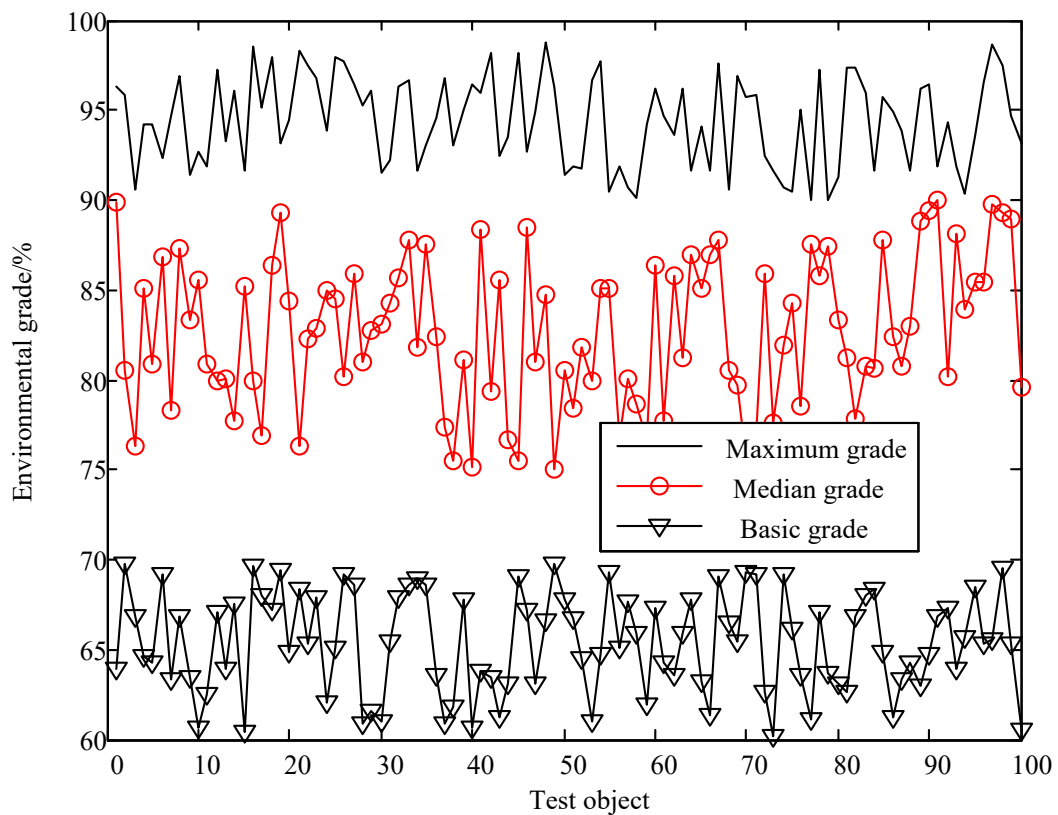

Fig. 5 Comparison of levels in rural tourist areas

The analysis shows that the evaluation level of eco-environment quality of human settlements by this model is higher. The comparison of expenditure and confidence level of eco-environment quality evaluation by different testing methods is shown in Figure 6 and Figure 7.

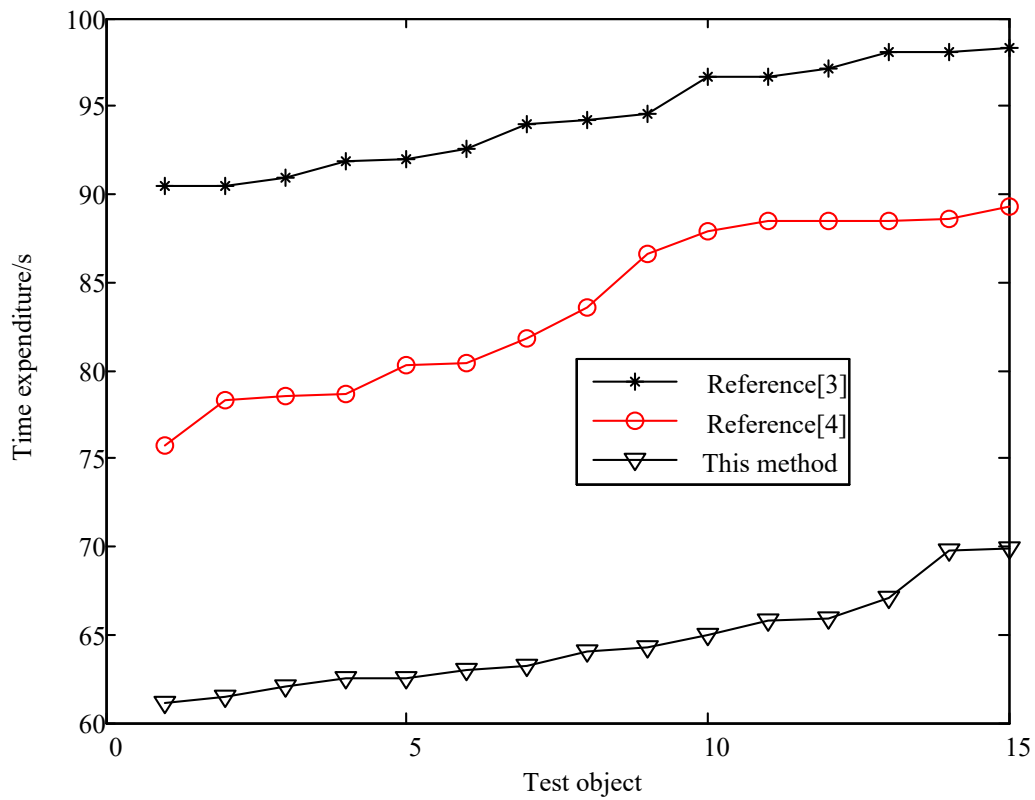

Fig. 6 Expenditure of eco-environment quality evaluation ecological adaptability

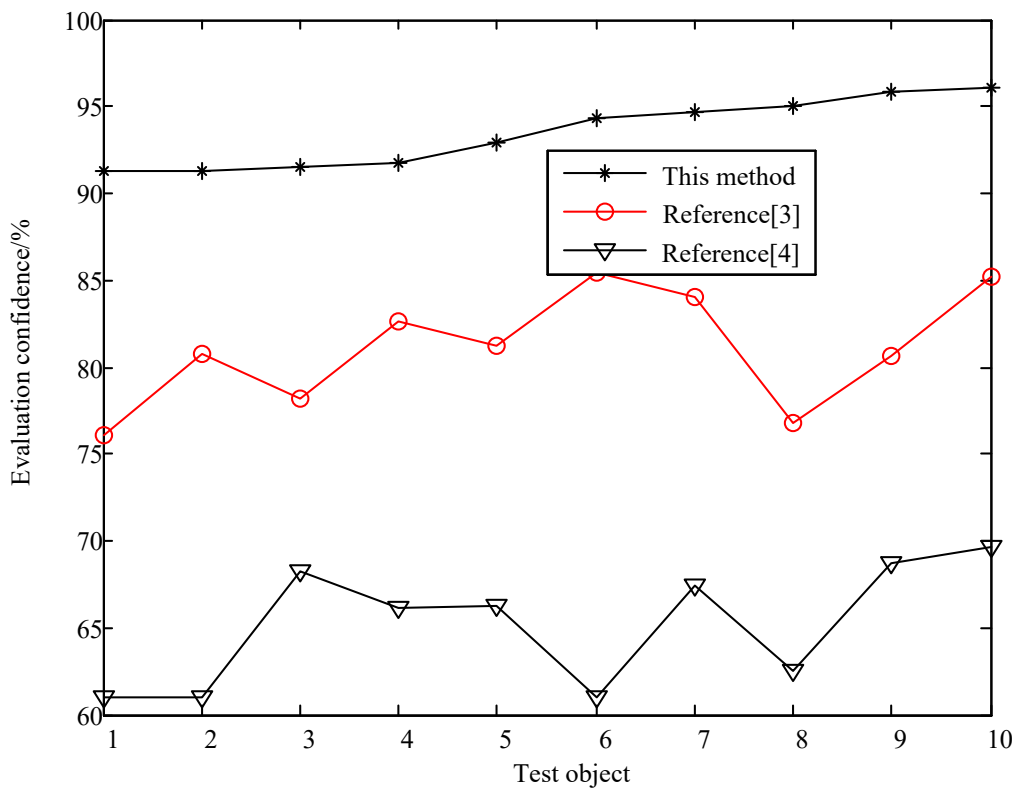

Fig. 7 Comparison of confidence level of eco-environmental quality evaluation in rural tourism areas

From Fig. 6 and Fig. 7 that the cost of eco-environment quality assessment in rural tourism areas in this method is less than 70s, and the confidence level is higher than 91%. Compared with the evaluation cost of reference [3] of 90s ~ 97s, the confidence level is 75% ~ 85%, and the evaluation cost of reference [4] of 75s ~ 89s, the confidence level is 60% ~ 70%. The evaluation cost of this method is lower and the confidence level is higher.

The life cycle cost comparison results of the eco-environmental quality improvement schemes of the three rural tourism areas are shown in table 2-4.

Table 2 Comparison results of life cycle cost of scheme I

| Number | Rural tourism area 1 | Rural tourism area 2 | Rural tourism area 3 |
|-----------------------------|----------------------|----------------------|--------------------------|
| Network topology | Reference method | [3]Reference method | [4]Methods in this paper |
| One time investment cost | 67.75 | 63.10 | 68.25 |
| Life cycle operation cost | 19.16 | 26.97 | 25.73 |
| Life cycle maintenance cost | 49.55 | 56.12 | 50.66 |
| Abandonment cost | 0 | 0 | 0 |
| Life cycle cost | 159.51 | 170.25 | 168.70 |

Table 3 Comparison results of life cycle cost of scheme II

| Number | Rural tourism area 1 | Rural tourism area 2 | Rural tourism area 3 |
|-----------------------------|----------------------|----------------------|--------------------------|
| Network topology | Reference method | [3]Reference method | [4]Methods in this paper |
| One time investment cost | 67.75 | 63.10 | 68.25 |
| Life cycle operation cost | 22.24 | 27.65 | 28.13 |
| Life cycle maintenance cost | 51.73 | 58.32 | 52.84 |
| Abandonment cost | 0 | 0 | 0 |
| Life cycle cost | 167.77 | 175.12 | 175.27 |

Table 4 Comparison results of life cycle cost of scheme III

| Number | Rural tourism area 1 | Rural tourism area 2 | Rural tourism area 3 |
|-----------------------------|----------------------|----------------------|--------------------------|
| Network topology | Reference method | [3]Reference method | [4]Methods in this paper |
| One time investment cost | 67.75 | 63.10 | 68.25 |
| Life cycle operation cost | 22.57 | 28.41 | 28.06 |
| Life cycle maintenance cost | 51.12 | 57.63 | 52.22 |
| Abandonment cost | 0 | 0 | 0 |

From the analysis of table 2-4, it can be concluded that the scheme with the lowest life cycle cost among the three eco-environmental quality improvement schemes in rural tourism areas is scheme 1. Under the same one-time investment cost, the operation cost and maintenance cost of scheme 1 are the lowest. It can be seen that scheme I can be selected finally according to the above evaluation results.

Collect the steady-state error experimental data in the eco-environment quality assessment and sort out the experimental results, as shown in Fig. 8.

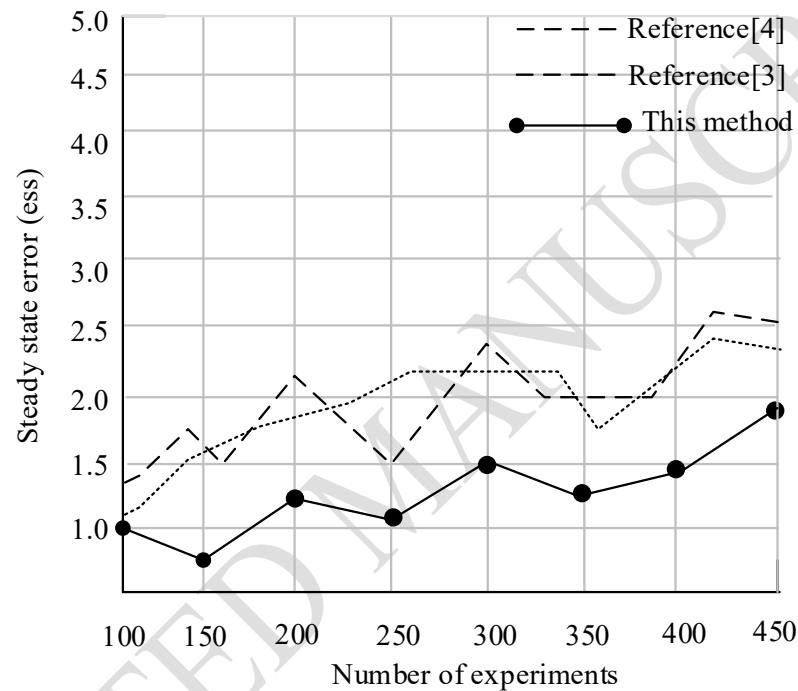

Fig. 8 Comparison of steady-state error of eco-environment quality

As shown in Fig. 8, the steady-state error of eco-environment quality under the design method in this paper is significantly lower than that of the two groups of comparison methods, and the accuracy is higher. Then collect and evaluate the experimental data of average risk value, and arrange them into a table. As shown in Table 5.

Table 5 Comparison data of evaluation average risk value

| Number of experiments | Methods in this paper | Reference [3] method | Reference [4] method |
|-----------------------|-----------------------|----------------------|----------------------|
| 100 | 0.561 | 2.587 | 1.687 |
| 150 | 0.247 | 1.897 | 0.997 |
| 200 | 0.208 | 2.457 | 1.557 |
| 250 | 0.268 | 3.054 | 2.154 |
| 300 | 0.358 | 2.986 | 2.086 |

| | | | |
|-----|-------|-------|-------|
| 350 | 0.407 | 2.657 | 1.757 |
| 400 | 0.536 | 3.457 | 2.557 |
| 450 | 0.368 | 2.664 | 1.764 |

As shown in Table 5, the average risk value of this method is significantly lower than that of the two groups of comparison methods, and the evaluation accuracy is higher. It can eliminate the unreliable data from the massive eco-environment quality data, avoid the problems in the traditional methods, and make the evaluation results more accurate.

4. Discussion

4.1. Problem

4.1.1. Uncontrolled development

In order to gain more space to develop rural tourism, - some people cut trees indiscriminately and destroy the surface vegetation at will, resulting in the reduction of the forest area, resulting in the reduction of the number and species of some animals and plants, - some wild animals were forced to migrate or disappear due to lack of food, the biodiversity of biological species was threatened, and the species of animals and plants were sharply reduced, resulting in the imbalance of the original balanced and stable ecosystem.

In order to obtain the maximum economic benefits, some rural tourism developers blindly develop and repeatedly construct rural tourism projects, which can not efficiently integrate rural tourism resources, resulting in a waste of rural tourism resources. Due to the repeated development and provision of tourism projects similar to other scenic spots, rural tourism products lack color, and rural tourism scenic spots lack complementarity, resulting in a reduction in the number of tourists and finally closing down, As a result, some township tourist attractions are idle there.

4.1.2. Tourism pollution Issues

In the rural tourism project of "eating farmhouse food" in the farmhouse entertainment, in order to ensure the delicious taste of farmhouse food, local residents cut down a large number of forests and cooked with chopped wood blocks. In the rural tourism project of self-help barbecue for tourists, chopped wood blocks are sold to tourists. However, some tourists are "eating" local forest resources while eating farmhouse meals and self-help barbecue. The process of wood block combustion will not only emit a large amount of carbon dioxide, but also emit those nitrogen oxides that pollute the environment, pollute the fresh rural tourism gas, and affect the air quality in the countryside. In order to improve the market competitiveness of the scenic spots, some agritainment tourist attractions sell some rare wild animals and plants to tourists under the banner of "eating characteristic wild game", and unilaterally interpret the new psychology of tourists as eating wild delicacies that are not available at ordinary times. If the tourists have demand, they can also provide information on the market to ensure that they can eat the "most distinctive" game. This kind of service behavior of selling "characteristic game" to tourists has led to the reduction of rare animals and plants, seriously damaged the rare wild

animals and plants resources, and seriously affected the ecological balance of the nature.

4.2. Countermeasures and suggestions

4.2.1. Promoting ecological civilization

Adhere to the concept of ecological civilization in rural development, innovate green production methods. We should break through the traditional extensive economic growth mode and gradually transform it into a green economic development mode with less impact on the eco-environment, less resource development and higher resource utilization rate, and control the location and scale of enterprises with large pollution and high energy consumption. Promote green and efficient agricultural production methods, reduce the application of pesticides and chemical fertilizers, implement agricultural water-saving projects, control environmental pollution and ecological damage from the source, effectively prevent agricultural pollution and improve the quality of agricultural products; According to local conditions, with the help of its own advantages, vigorously develop rural tourism, gradually guide the development of rural tertiary industry, and take the road of sustainable development.

4.2.2. Stakeholder Environmental Responsibility

Good eco-environment is the foundation of sustainable development in rural areas. To promote rural eco-environment governance and realize all-round rural revitalization, it is necessary for "stakeholders" to fulfill their respective responsibilities and "multi governance". Township enterprises and villagers are all stakeholders. Change the development concept of township enterprises, establish green ecological processes, promote clean production, and minimize the adverse impact of production and operation activities on the eco-environment. Strengthen the publicity and training of employees' eco-environment protection knowledge, enhance their awareness of environmental protection responsibility, and encourage them to consciously assume the responsibility of environmental protection. Villagers are not only the main force of eco-environment improvement, but also the main beneficiaries. Therefore, it is necessary to strengthen the publicity of eco-environment protection and construction knowledge in rural areas, improve farmers' environmental protection awareness and literacy, give farmers more right to know about the environment, make farmers realize that the quality of eco-environment is closely related to their own quality of life, guide farmers to actively participate in environmental protection, practice green production and lifestyle, and reduce eco-environment pollution and damage.

6. Conclusions

In this paper, the index vector group of the quantitative evaluation of the ecological environment quality of the tourist destination is established to realize the evaluation and feature extraction of the ecological environment quality of the tourist destination. On this basis, through multi-level and multi-level comprehensive integration, the evaluation index system of rural tourism regional ecological environment quality based on multi-level and multi-scale is established, and through multi-level and multi-level collaborative optimization, the ecological environment evaluation of different levels, different types and different levels is realized. Different eco-environment quality scores were found in

the simulation analysis conducted between July 2016 and April 2022 using Matlab 7 and Visual C++. These scores included those for urban-rural integration (0.719), natural resource utilization (0.456), ecological parameters in rural planning (0.650), and ecological tourism planning (0.812). The evaluation costs were less than 70s, with a confidence level higher than 91%. This was better than the references [3] (90s-97s, 75%-85% confidence) and [4] (75s-89s, 60%-70% confidence). Out of all the rural tourism locations, Scheme I showed the lowest life cycle costs: one-time investment (67.75), operation (19.16), maintenance (49.55), and totaling 159.51. By using factor assessment method and neural network classifier, the characteristics of ecological environment quality assessment in rural tourism areas are classified, and the evaluation of ecological environment quality in rural tourism areas is completed by comprehensive use of univariate descriptive statistics and mean test. Through simulation calculation, the reliability of the proposed method is verified, and the feasibility of the proposed method is proved. Methods The ecological adaptability of rural tourism destinations in China was evaluated.

Data Availability

The raw data supporting the conclusions of this article will be made available by the authors, without undue reservation."

Conflicts of Interest

The authors declared that they have no conflicts of interest regarding this work."

Author Contributions:

The research conception and design, data collection and result analysis were all completed by Hui Yang himself.

Funding

This work supported by Social Science Foundation of Jilin Province (general self-selected project) "Research on the Development Mechanism and Path of Rural Tourism in Jilin Province from the perspective of High Quality Development" (2021B79); Social Science Foundation of Jilin Province (Key project) "Dynamic Mechanism and Realization Path of High-quality Development of Snow and Ice Industry in Jilin Province" (2021A21); Social Science Foundation of Jilin Province (Doctor and Youth Support Project) "Research on the Integration of Regional Protection and Utilization of Anti-resistance Remnants in Jilin Province" (2021C55); Jilin Provincial Education Department Humanities and Social Science Research "13th Five-Year Plan" Project "Research on the Development Optimization Path of Jilin Province Ice and Snow Tourism Industry under the Background of" One Major, Six Double "Strategy" (JJKH20211382SK)

Author Contributions:

The data query, demonstration and result analysis of this paper are all completed by teacher Yang Hui alone.

References

- [1] Wang MuxuNan FangLu Hua, et al. Study on ecological landscape and habitat adaptability in the underground mountains of Yunnan plateau[J]. Shanxi Architecture, 2020, 46(4): 40-42.
- [2] Zhang Gejuan, He Zhenying. Evaluation of Complex Ecological System of Traditional Village

- Human Settlements in Weibei Area of Guanzhong[J]. *Journal of Chinese Urban Forestry*, 2021, 19(6): 76-81,109.
- [3] SHEN Xuezheng, JIN Yujie, SU Zhucheng. Quantitative Analysis on Brand Premium Factors of Tea Enterprises Based on AHP and PSO[J]. *Journal of Tea Science*, 2020, 40(1): 133-142.
- [4] YU Ting, SUN Jingyun. Forecast of Container Throughput of Chinese Ports Based on EEMD and PSO[J]. *Logistics Technology*, 2021, 40(5): 56-64.
- [5] CHEN Shuang, ZHANG Qiao. Industrial robot absolute distance self-calibration method based on PSO algorithm[J]. *Manufacturing Automation*, 2021, 43(4): 30-34.
- [6] GUO Ying, CUI You-xiang, ZHANG Luo-xin. Evaluation of marine fishery ecological environment quality based on Two-stage Model, Fuzzy Set & QFD[J]. *Chinese Fisheries Economics*, 2020, 38(3): 47-56.
- [7] LIN Shuwei, GUAN Songli. The study on evaluation of visual environment quality of urban ecological park[J]. *Journal of Yanbian University(Natural Science)*, 2020, 46(3): 270-276.
- [8] ZHAO Lu, JIN Hong, XUE Lian. Quality Evaluation and Ranking of Main Surface Water in Qingdao Based on Single-factor Evaluation Method and City Water Quality Index Method[J]. *China Resources Comprehensive Utilization*, 2022, 40(2): 68-70.
- [9] DONG Han-yuan. Analysis of Investment Environment Evaluation in Northwest China Based on Factor Analysis[J]. *Economig Rfsearch Cuide*, 2022, 18(18): 94-96.
- [10] TANG Huan, HU En-Liang. A robust fuzzy clustering method[J]. *Journal of Yunnan University of Nationalities(Natural Sciences Edition)*, 2020, 29(4): 361-365.
- [11] ZHANG Jian, YAN Haowen, WANG Zhuo, et al. Mining algorithm of We-map users association rule under the constraint of communication capacity[J]. *Science of Surveying and Mapping*, 2022, 47(1): 227-235.
- [12] ZHAO Man, GUO Yi-xin, HE Yu-qing, et al. Baseline Correction of UV Raman Spectrum Based on Improved Piecewise Linear Fitting[J]. *Spectroscopy and Spectral Analysis*, 2020, 40(6): 1862-1868.
- [13] HU Zhi-jie, LUO Ze-peng, HU Yu-mo. Research on strip noise separation of ship remote sensing image based on multivariate linear fitting[J]. *Ship Science and Technology*, 2022, 44(7): 182-185.
- [14] LUO Da-rong, XIAO Jian-hua. A Quantitative Method for Evaluating City-Industry Integration[J]. *Journal of Wuyi University(Natural Science Edition)*, 2022, 24(1): 35-41.
- [15] KONG Pei, LIU Jianfeng, ZHOU Jian, et al. Fault-tolerant algorithm for fault location in distribution network based on integer linear programming[J]. *Power System Protection and Control*, 2020, 48(24): 27-35.
- [16] LI Jinsong, PENG Jianhua, LIU Shuxin, et al. A Link Prediction Method in Directed Networks Via Linear Programming[J]. *Journal of Electronics & Information Technology*, 2020, 42(10): 2394-2402.
- [17] ZHAO Yun-duo. Research on Sand and Gravel Supply of Box Girder Prefabrication Plant along River based on Linear Programming Mathematical Model Algorithm[J]. *Railway*

- Engineering Cost Management, 2021, 36(1): 46-51.
- [18] YUN Li, BAI Caihong, XU Wenfen, et al. Correlation analysis between magnoflorine content in *Dichocarpum dalzielii* and environmental factors based on multivariate statistical analysis[J]. *Guizhou Science*, 2022, 40(1): 32-38.
- [19] LIU Feng-yan, BAO Si-yao, XIA Shu-xian, et al. Research on Citizens' willingness to Buy Fresh Food Online Based on MultiVariate Statistical Analysis[J]. *Journal of Tonghua Normal University*, 2021, 42(4): 30-36.
- [20] Xue Cheng, Wang Cheng. Test and Analysis on the Exchange Rate Volatility Interactive Spillover Effects Based on "Delta method"[J]. *Future and Development*, 2020, 44(5): 99-109.
- [21] Ghyasuddin Hashmi, Syed, V. Balaji, Mohamed Uvaze Ahamed Ayoobkhan, Mohammad Shabbir Alam, R. Anilkuamr, Neerav Nishant, Jyoti Prasad Patra, and A. Rajaram. Machine Learning-Based Renewable Energy Systems Fault Mitigation and Economic Assessment." *Electric Power Components and Systems*, 2024: 1-24.
- [22] WANG Shan-shan, GAO Xin-qin, ZHANG Hui, et al. Feature extraction and association analysis method of text information for cloud manufacturing resources[J]. *Manufacturing Automation*, 2020, 42(9): 9-13,134.
- [23] Pradeep, Jayarama, S. Raja Ratna, P. K. Dhal, K. V. Daya Sagar, P. S. Ranjit, Ravi Rastogi, Vigneshwaran K, and A. Rajaram. DeepFore: A Deep Reinforcement Learning Approach for Power Forecasting in Renewable Energy Systems. *Electric Power Components and Systems*, 2024: 1-17.
- [24] CHANG Siwei. Psychological big data evaluation method based on feature extraction of association rules[J]. *Journal of Zhoukou Normal University*, 2020, 37(2): 144-147.
- [25] ARULSELVAN, G., and A. RAJARAM. AN OPTIMISED DATA ACCUMULATION TECHNIQUE USING NODE SELECTION IN AN AD HOC NETWORK FOR ENVIRONMENTAL MONITORING. *Journal of Environmental Protection and Ecology [J]* 23, no. 8,2022: 3564-3573.
- [26] ZHANG Jigang, LI Xiang, WU Lei. Design of Comprehensive Evaluation Model for Power Supply Quality Based on Analytic Hierarchy Process[J]. *Microcomputer Applications*, 2021, 37(10): 94-97.
- [27] Arulselvan, G., and A. Rajaram. Hybrid trust-based secure routing protocol for detection of routing attacks in environment monitoring over MANETs. *Journal of Intelligent & Fuzzy Systems [J]*. Preprint 2023: 1-16.
- [28] QIN Peng, JIA Hong-jie, HUO Xing-ying, et al. User Personalized POI Recommendation Method Integrating Big Data Mining[J]. *Computer Simulation*, 2022, 39(6): 355-358,385.
- [29] Komala, C. R., V. Velmurugan, K. Maheswari, S. Deena, M. Kavitha, and A. Rajaram. Multi-UAV computing enabling efficient clustering-based IoT for energy reduction and data transmission. *Journal of Intelligent & Fuzzy Systems [J]* 45, no. 1 2023: 1717-1730.
- [30] WEI Guozhong. An Adaptive Spatial Weight Markov Random Field Fuzzy Clustering for Hyperspectral Images[J]. *Remote Sensing Information*, 2020, 35(6): 32-37.

- [31] Gupta, Shivani, Nileshkumar Patel, Ajay Kumar, Neelesh Kumar Jain, Pranav Dass, Rajalaxmi Hegde, and A. Rajaram. Adaptive fuzzy convolutional neural network for medical image classification. *Journal of Intelligent & Fuzzy Systems [J]*. Preprint 2023: 1-17.
- [32] XIAO Mansheng, ZHANG Longxin, ZHANG Xiaoli, et al. An Improved Fuzzy Clustering Method for Interval Uncertain Data[J]. *Journal of Electronics & Information Technology*, 2020, 42(8): 1968-1974.

ACCEPTED MANUSCRIPT